



www.phytron.com/ZSS

ZSS Stepper Motors

For Applications with Extended Temperature Range

RoHS
compliant

The proven 2-phase hybrid stepper motors series ZSS combine highest precision with smooth running characteristics. With up to 102.400 approachable positions (200-step motor, driven in micro stepping mode with 1/512 step resolution and encoder) the ZSS motor provides your application with highest precision positioning capabilities.

The ZSS Serie differs from standard market motors by the extended ambient temperature range from -30 to +80 °C.

Thus, the motor is suitable for the most demanding applications in diverse areas of application.

Perfect-fit for your application:

- with gear
 - GPL low-backlash planetary gears
 - PLG planetary gears
 - HD Harmonic Drive gears
 - GSR worm gears
- with motor brake
 - Permanent magnet brake for 24 V_{DC} supply voltage
- with encoder
 - Standard resolution 500 lines
 - 3-channel optical incremental encoder

In Focus



high precision



temperature



smooth running

- 2-phase hybrid stepper motors
- 200-step (step angle 1.8°)
- Standard connection: 4-lead parallel
- Connection options:
 - 4-lead in series
 - 5-, 6- or 8-lead connection
- Holding torques from 3.8 to 700 mNm
- Variable cable output: axial or radial
- Protection class
 - IP 40 for ZSS with free wire ends
- Perm. ambient temperature -30 to +80 °C
- Max. operating voltage of the power stage (Intermediate circuit voltage: 70 V_{DC})
- Insulation class F acc. to VDE 0530
- Test voltage
 - ZSS 19 to 52: 700 V (1 min)
 - ZSS 56 to 57: 1500 V (1 min)
- Optional:
 - 2nd shaft (IP 40)
 - encoder
 - motor brake
- Customised shaft design
- Special windings

Highlights



temperature

Extended Temperature Range

The ZSS stepper motor not only convinces with a very balanced, smooth and low resonance running performance with maximum positioning accuracy, but also with the extended ambient temperature range of -30 to +80 °C.



Options

Variety of expansion stages

With a variety of options and the high level of vertical integration of phytron, the ZSS is the ideal basis for customised applications. Gears, brakes, encoders, shaft or flange adjustments or special windings - the ZSS offers the optimum basis for efficient customising.

Industrial

Stepper motor ZSS 19 to ZSS 57

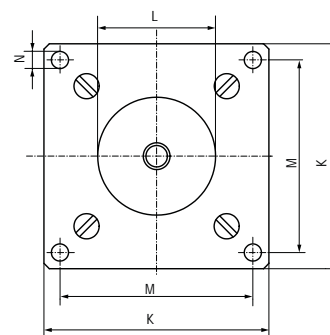
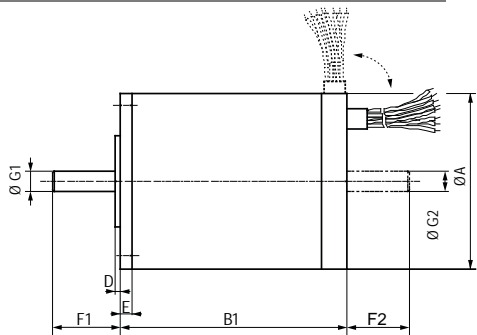

Dimensions / Electrical and Mechanical Characteristics

ZSS Standard 200-steps 4 lead parallel ¹⁾	Electrical Characteristics				Mechanical Characteristics							Dimensions in mm											
	Current/Phase In	Resistance/ Phase	Inductivity/ ³⁾ Phase	max. operating voltage ⁴⁾	AWG	Holding torque ²⁾	Detent torque	Rotor inertia	Loads		Mass												
									axial	radial		A	B1	D	E	F1	F2	G1 ⁵⁾	G2 ⁵⁾	K	L	M	N
19.200.0.6 19.200.1.2	0.6 1.2	1.85 0.63	0.55 0.15	70	28	3.8	0.9	0.0009	3	3	0.04	19	26.5	1	2	7.5	6.5	2.5	2.5	19	10	16	M2.5
20.200.0.6 20.200.1.2	0.6 1.2	3.45 0.95	1.1 0.4		28	5	1	0.0016	3	3	0.065	19	43	1	2	7.5	6.5	2.5	2.5	19	10	16	M2.5
25.200.0.6 25.200.1.2	0.6 1.2	3.25 0.95	1.5 0.4		26	13	2	0.0025	5	5	0.07	25	31	1	2.5	9.5	8.5	3	3	25	14	21.5	2.2
26.200.0.6 26.200.1.2	0.6 1.2	5.85 1.7	3.2 1		26	25	2.2	0.006	5	5	0.11	25	47	1	2.5	9.5	8.5	3	3	25	14	21.5	2.2
32.200.0.6 32.200.1.2	0.6 1.2	4.5 1.25	5.3 1.2		26	50	3	0.01	5	15	0.15	32	38.5	1	3	11	10	4	4	32	18	27	2.8
33.200.0.6 33.200.1.2	0.6 1.2	7.5 1.9	9.3 2.2		26	75	3.3	0.018	5	15	0.23	32	57.5	1	3	11	10	4	4	32	18	27	2.8
41.200.1.2 41.200.2.5	1.2 2.5	1.35 0.27	2 0.4		22	100	4	0.025	20	40	0.26	42	39	1	3	16	15	5	4	42	22	36	3.2
42.200.1.2 42.200.2.5	1.2 2.5	1.7 0.34	3 0.7		22	140	5	0.045	20	40	0.32	42	54	1	3	16	15	5	4	42	22	36	3.2
43.200.1.2 43.200.2.5	1.2 2.5	2.6 0.5	5.2 1.2		22	260	7	0.077	20	40	0.47	42	69	1	3	16	15	5	4	42	22	36	3.2
⁴⁾ 52.200.1.2 ⁴⁾ 52.200.2.5	1.2 2.5	2.65 0.6	7 1.6		22	450	13	0.15	25	70	0.65	52	65	1.5	3.5	17.5	16	6	4	52	28	44	4.3
⁴⁾ 56.200.1.2 ⁴⁾ 56.200.2.5	1.2 2.5	2.85 1.65	6.7 1.7		22	500	30	0.17	40	80	0.7	56.4	58.1	1.5	4.5	22	20.5	6.35	6.35	60	38.1	47.15	5.2
⁴⁾ 57.200.1.2 ⁴⁾ 57.200.2.5	1.2 2.5	3.9 0.8	7.8 2.4		22	700	50	0.24	40	80	0.9	56.4	74.1	1.5	4.5	22	20.5	6.35	6.35	60	38.1	47.15	5.2

¹⁾ other step resolutions on demand (with different mechanical characteristics!)
²⁾ Holding torque in bipolar mode with parallel windings, two phases on rated current
³⁾ The inductivity values apply for each single winding as well as for parallel connected windings.
⁴⁾ ZSS 52, 56 and 57 with earthing screw on the terminal board.

⁵⁾ Shaft diameter tolerances: ZSS 19 to 26: -0.005 to -0.009; from ZSS 32: g5
⁶⁾ max. operating voltage of the power stage (intermediate circuit voltage)
 All values given above refer to room temperature.
Preferred option

Electrical Connection / Connection Types / Phase current

The phytron stepper motors type ZSS are built in 4-lead parallel windings (standard).

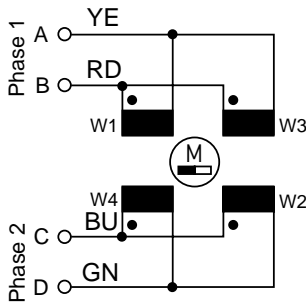

4-lead parallel / winding bipolar

Alternative windings such as 8-lead are available on request:

The motors can be used with unipolar or bipolar control mode, as the windings can be differently connected.

5- lead or 6-lead connection are applicable for the unipolar control mode.

In the bipolar control mode, 4-lead motor wiring is required, windings connected in parallel or in series.

The information in the ZSS motor connection leaflet (delivered with each motor) must be regarded when wiring the motor in order to provide for EMC compliant wiring. The motor connection leaflets are also available by down-load from the phytron homepage.

Phase currents

For ZSS phytron stepper motors, the rated current [A] per motor phase is printed on the rating plate. The last digits of the motor's type number define the rated current.

Example: ZSS 32.200.1,2

The **rated current** is defined for full step operation, at bipolar control mode, with parallel connected motor windings.

According to the connection mode, the motor windings receive different currents. Therefore, for identical power dissipation in the motor, the allowable phase current is determined by the connection mode.

For short time, double current overload is acceptable.

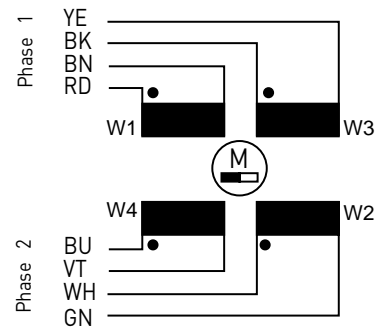

ZSS with free wire ends

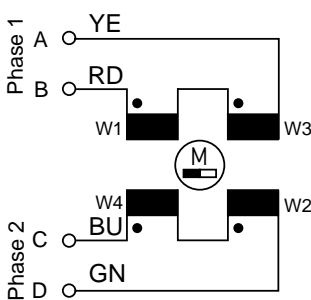

4-lead / serial windings / bipolar

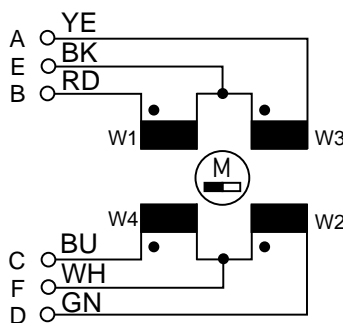

6-lead / unipolar mode

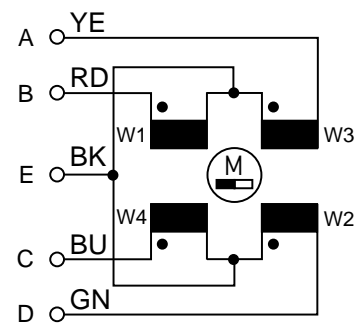

5-lead / unipolar mode

Control mode	Bipolar control mode Full step operation		Unipolar control mode Full step operation	
Motor connection	4-lead parallel windings Standard wiring for bipolar control mode	4-lead serial windings	5-lead	6-lead
Allowable phase current for identical power dissipation	Rated current	Rated current x 0.5	Rated current x 0.707	Rated current x 0.707

Industrial

Option: Stepper Motor with Encoder

The stepper motors ZSS 25 to ZSS 57 with mounted encoder are particularly suitable for use in control actuators or for system monitoring.

- Motor connection by free wire ends
- Encoder connection with flat cable with 12-pin connector
- Protection class IP20

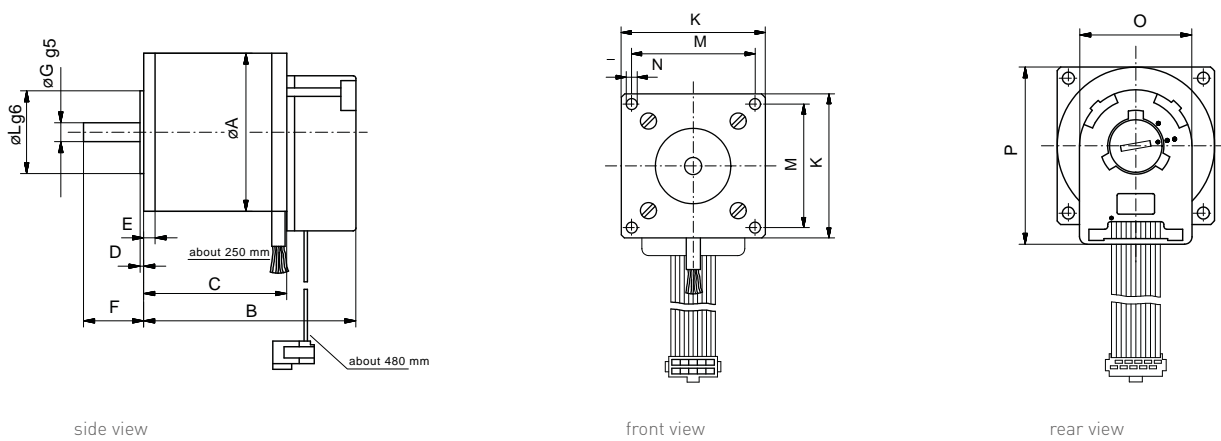

Encoder	Stepper motor	Dimensions in mm												
		A	B	C	D	E	F	G	K	L	M	N	O	P
HEDL 5540	ZSS 25 ZSS 26	25	49.5	31	1	2.5	9.5	3	25	14	21.5	2.2	30	41.1
	ZSS 32 ZSS 33	32	57.5	39	1	3	11	4	32	18	27	2.8	30	42.2
	ZSS 41 ZSS 42 ZSS 43	42	57.5	39	1	3	16	5	42	22	36	3.2	30	47.2
	ZSS 52	52	83.5	65	1.5	3.5	17.5	6	52	28	44	4.3	30	-
	ZSS 56 ZSS 57	56.4	77	58.1	1.5	4.5	22	6.35	60	38.1	47.15	5.2	30	-
	ZSS 56 ZSS 57	56.4	93	74.1	1.5	4.5	22	6.35	60	38.1	47.15	5.2	30	-

Option: Stepper Motor with Motor Brake

For the stepper motors ZSS 32 to ZSS 57 a mounted 24 V_{DC} permanent magnet motor brake is optionally available.

ZSS 32 to 43: KEB 01: Power 8 W / Nominal torque 0.4 Nm; electrical connection: free wire ends

ZSS 52 to 57: KEB 02: Power 10 W / Nominal torque 1 Nm; electrical connection: circular connector

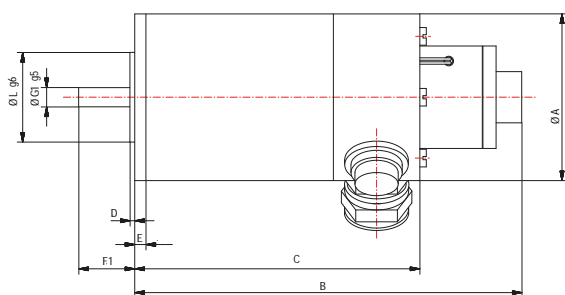

Side view

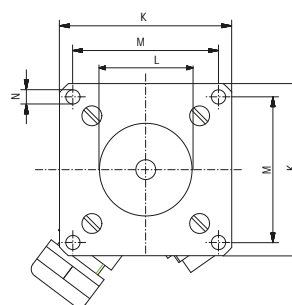

Front view

Motor brake	Stepper motor	Dimensions in mm										
		A	B	C	D	E	F1	G1	K	L	M	N
KEB01	ZSS 32	32	72	43	1	3	11	4	32	18	27	2.8
	ZSS 33	32	91	62	1	3	11	4	32	18	27	2.8
	ZSS 41	42	104	71.5	1	3	16	5	42	22	36	3.2
	ZSS 42	42	124	86.5	1	3	16	5	42	22	36	3.2
	ZSS 43	42	139	101.5	1	3	16	5	42	22	36	3.2
KEB02	ZSS 52	52	121	89	1.5	3.5	17.5	6	52	28	44	4.3
	ZSS 56	56.4	112	79.6	1.5	4.5	22	6.35	60	38.1	47.15	5.2
	ZSS 57	56.4	128	95.6	1.5	4.5	22	6.35	60	38.1	47.15	5.2

Option: Stepper motor with Heat Sink

The ZSS stepper motors are also available with a mounted heat sink. Depending on the motor's mounting position, a heat sink with radial fins (K1) or axial fins (K2) can be selected.

The use of a K1 heat sink increases the stepper motor's thermal dissipation surface by a factor of approx. 3.9. With a K2 heat sink, it is increased by a factor of approx. 3.4.

A heat sink can be mounted subsequently, preferable by phytron.

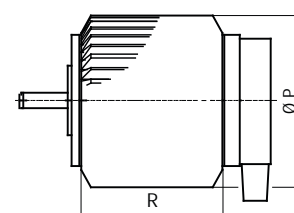
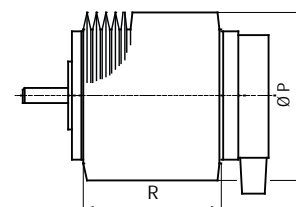

Stepper motor	Dimensions											
	ZSS 19	ZSS 20	ZSS 25	ZSS 26	ZSS 32	ZSS 33	ZSS 41	ZSS 42	ZSS 43	ZSS 52	ZSS 56	ZSS 57
P	26	26	35	35	42	42	55	55	55	65	78	78
R	20.5	37	24	40	30	49	30	45	60	58	44	60

Industrial

Option: Stepper Motor with GPL Low-backlash Planetary Gear

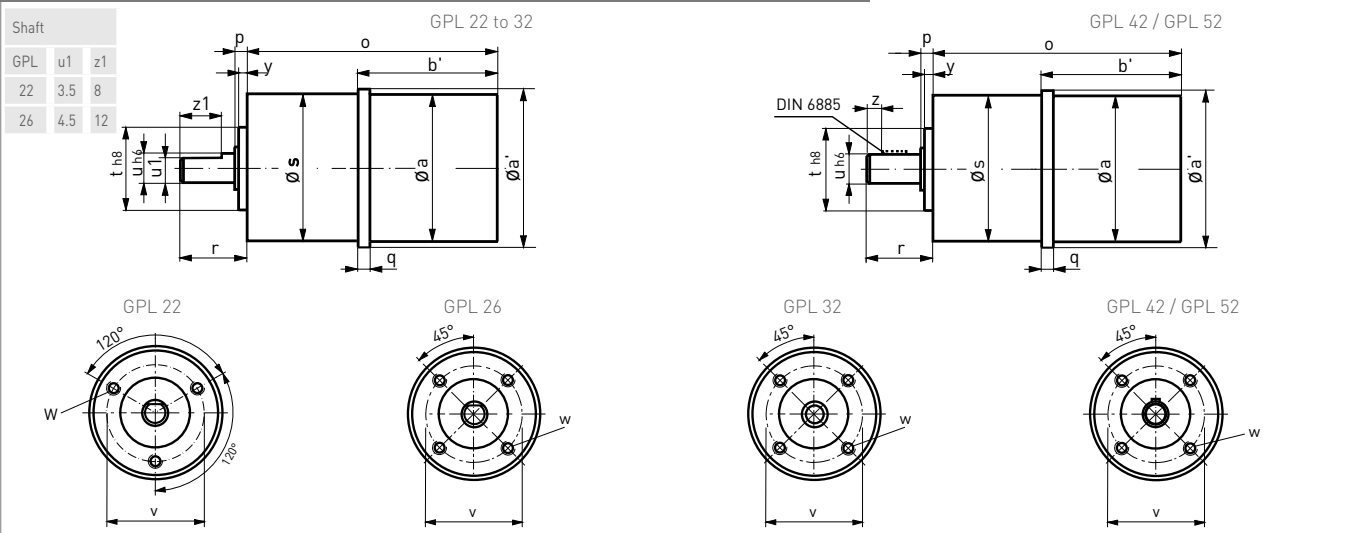

Gaer	Stepper motor	Dimensions in mm																
		a	a'	b'	o			p	q	r	s	t	u	v	w	x	y	z
GPL 22	ZSS 19 ZSS 20	19	22	29 45.5	50 66.5	57 73.5	64 80.5	2.5	4.5	15	22	12	4	16	M2.5x4	-	0.5	-
	ZSS 25 ZSS 26	25	25.5	33.5 49.5	54.5 70.5	61.5 77.5	68.5 84.5		5									
GPL 26	ZSS 25 ZSS 26	25	26	33.5 49.5	59 75	67 83	75 91	2.5	5	17	26	14	5	20	M3x4	-	0.5	-
	ZSS 32 ZSS 33	32	33	40.5 59.5	69.5 88.5	78.5 97.5	87.5 106.5		4									
GPL 42	ZSS 41	42	43	53	88	100.5	113	4	7	22.5	42	25	8	32	M4x8	3x3x14	1	2.25
	ZSS 42			68	103	115.5	128											
	ZSS 43			83	118	130.5	143											
GPL 52	ZSS 52	52	53	82.5	123.5	138	152.5	4	9	24	52	32	12	40	M5x8	4x4x16	1	2
	ZSS 56			73	114	128.5	143											
	ZSS 57			89	130	144.5	159											

Mass / Permissible Loads / Protection Class

Gear	Mass without motor			Perm. radial load (center of shaft)	Permissible axial load	Protection class	Protection class gear + motor
	1-stage	2-stage	3-stage				
	g			N	N		
GPL 22	50	75	100	30	24	IP 44	IP 40 IP 44
GPL 26	70	90	115	50	40	IP 44	IP 40 IP 44
GPL 32	135	180	250	80	65	IP 54	IP 40 IP 44
GPL 42	275	350	425	150	120	IP 54	IP 43 IP 65
GPL 52	475	600	725	250	200	IP 54	IP 43 IP 65

[IP xx = Standard](#) IP xx = optional (dimensions on request)

GPL Gear Mechanical Characteristics

Gear	Stepper motor	Mechanical gear characteristics											
		Stages	Reduction ratios		Standard			Low-backlash			Torsional stiffness	Average mass inertia at output	Efficiency (%)
					No-load backlash	Nominal torque (S1)	Emergency stop torque	No-load backlash	Nominal torque (S5)	Emergency stop torque			
					Nm			Nm					
GPL 22	ZSS 19 ZSS 20 ZSS 25 ZSS 26	1	4:1 5:1	7:1	20'	0.1	0.2	-	-	-	0.19	0.008	96
		2	16:1 20:1 28:1	35:1 49:1	35'	0.5	1	-	-	-	0.21	0.006	90
		3	64:1 80:1 112:1	140:1 196:1 245:1	50'	1.5	3	-	-	-	0.2	0.004	85
GPL 26	ZSS 25 ZSS 26	1	3.5:1 4.33:1	6:1 7.67:1	20'	0.3	0.6	-	-	-	0.24	0.012	96
		2	12.25:1 18.78:1 26:1	33.22:1 46:1	35'	1	2	-	-	-	0.26	0.010	90
		3	81.37:1 112.67:1 143.96:1	199.33:1 276:1	50'	3	6	-	-	-	0.25	0.0095	85
GPL 32	ZSS 32 ZSS 33	1	4:1 4.5:1 5.2:1	6.25:1 8:1	20'	0.4	0.8	6'	0.8	1.6	0.3	0.015	96
		2	16:1 18:1 20.8:1 25:1 29:1	32:1 36:1 41.6:1 50:1	35'	2	4	10'	4	6	0.32	0.012	90
		3	72:1 81:1 100:1 130:1	144:1 200:1 225:1 256:1	50'	6	12	15'	6	12	0.3	0.011	85
GPL 42	ZSS 41 ZSS 42 ZSS 43	1	4:1 5:1	6:1	20'	0.7	1.4	6'	1.4	3	0.4	0.03	96
		2	14:1 16:1	20:1	35'	4	8	10'	8	12	0.42	0.024	90
		3	56:1 64:1 80:1 100:1	120:1 144:1 184:1	50'	12	24	15'	12	24	0.4	0.024	85
GPL 52	ZSS 52 ZSS 56 ZSS 57	1	4:1 4.5:1 5.2:1	6.25:1 8:1	20'	1.5	3	6'	3	6	1.2	0.06	96
		2	16:1 18:1 20.8:1 25:1 29:1	32:1 36:1 41.6:1 50.1:1	35'	10	20	10'	20	30	1.3	0.055	90
		3	72:1 81:1 100:1 130:1	144:1 200:1 225:1 256:1	50'	30	60	15'	30	60	1.35	0.05	85

1) Valid for 21 °C ambient temperature

Stepper Motor with GPL Gear

- Stepper motor mounted gear
- 1- to 3-stage planetary gear
- Low gear backlash
 - Standard: 20 to 50 arcmin
 - Low-backlash: 6 to 15 arcmin
- Maximum permanent torque 0.1 to 38 Nm
- 100% permissible short-term overload
- Adapted for permanent, alternate or intermittent operation
- Ideal for combinations with toothed belt modules
- 4:1 to 256:1 reduction ratios (depending on the gear type)
- High efficiency
- Low gear inertia
- Perm. temperature range -30 to +90°C
- Maintenance-free permanent lubrication

Gear Material

- Gear housing
 - GPL16 and 22: stainless steel
 - GPL 26 to 52: rustproof for normal environmental conditions
- Output shaft: 2 deep groove ball bearings

Gear Operating Modes

1: Continous operation
The gear box's operating time exceeds 15 minutes without a break or the duty cycle is more than 60%. In no case the gear box housing temperature may exceed 70 °C.

S5: Cyclical operation
The gear box's duty cycle is less than 60%. The number of operations per hour can range anywhere from a few to several thousand. If the number of operations exceeds 1000 per hour, the maximum torque occurring has to be multiplied by a shock factor to take into account the additional dynamic load. The data in this publication are based on software models and empirical values and on a shock factor of 1.25.

Shock Factor for Cyclical Operation (S5)

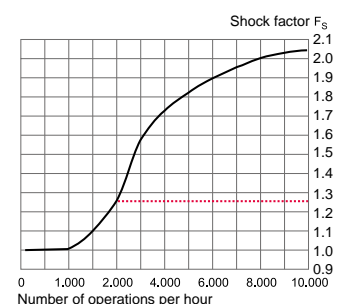

Industrial

ZSS Stepper motor with HD Gear

The Harmonic Drive gears are based on a totally new operating principle. The transmission force is exerted by a resilient deformable toothed steel cylinder flexspline which transmits the motor rotation to the drive shaft. Drive shaft and output shaft direction is opposed.

Backlash and torsional stiffness

Harmonic Drive® gears have particularly low backlash. In practice, the tooth-contour backlash can be neglected (see page 9). The total gear torsion is equal to the sum of $\frac{1}{2}$ backlash + torque/resilient constant.

HD Gear

- with mounted stepper motor ZSS 25 to ZSS 52
- Reduction ratio depending on size 50:1, 80:1, 100:1
- High reduction ratio in a small volume
- Low weight
- Low mass inertia
- High permissible torque, in comparison to the size
- High drive speed Very low backlash in comparison to conventional gears
- High efficiency

HD 05 to 14

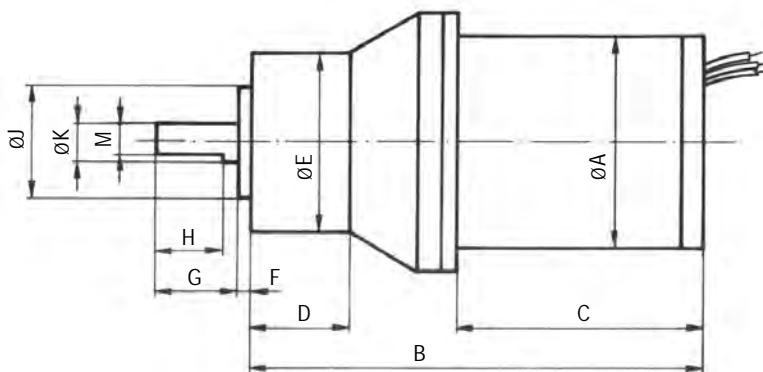

HD 05 to 08

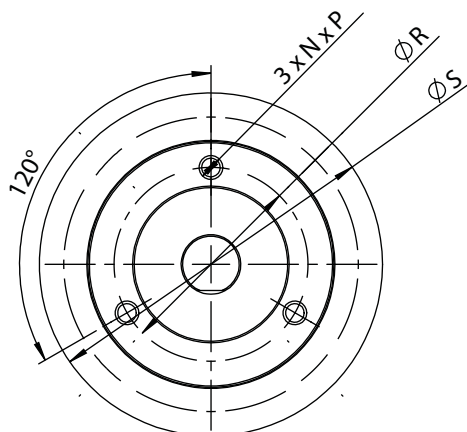

HD 11 to 14

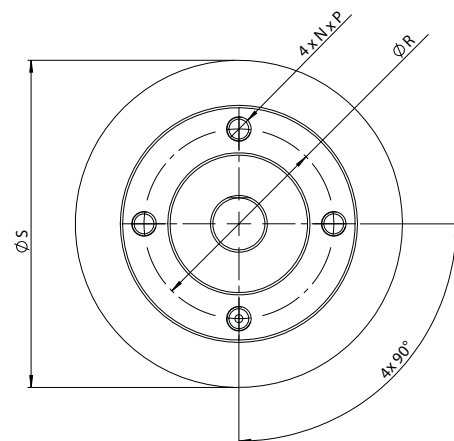

Dimensions and Mechanical Characteristics

Gear	Stepper motor	Dimensions in mm														Mass Motor with gear kg	Reduction ratio	Max. permissible off drive torque Nm	Max. permissible speed 1/min	Massenträgheitsmoment Getriebe ¹⁾ kg cm ²	Max. zulässige Radialkraft N	Max. zulässige Axialkraft N	Zahnflankenspiel min	Federkonstante Nm/in	
		A	B	C	D	E	F	G	H	J	K	M	N	P	R										S
HD 05	ZSS 25 ZSS 26	25	53.9 69.9	28.5 44.5	11.9	20	1	10	9	13.5 _{h6}	5 _{h6}	4.6	M2	6	16.4	32	0.09 0.15	80:1	0.3	9000	2.5 x 10 ⁻⁴	60	30	0.4 - 4	0.023
HD 08	ZSS 32 ZSS 33	32	81.2 100.2	35.5 54.5	26.7	33	1.8	20	18	21 _{h6}	8 _{h6}	7.5	M3	6	26	46	0.28 0.35	50:1 100:1	1.5 2.0	6000	0.003	200	100	0.4 - 4	0.16 0.2
HD 11	ZSS 41	42	99.5	42	30.5	40	3	22	20	24 _{h7}	10 _{h6}	9.5	M4	7.5	34	58	0.53	50:1 100:1	2.5 4.0	5000	0.012	250	200	0.4 - 3	0.3 0.36
	ZSS 42	42	115.5	58	30.5	40	3	22	20	24 _{h7}	10 _{h6}	9.5	M4	7.5	34	58	0.59								
	ZSS 43	42	130.5	73	30.5	40	3	22	20	24 _{h7}	10 _{h6}	9.5	M4	7.5	34	58	0.74								
HD14	ZSS 52	52	136	73.5	41	50	3	25	23	30 _{h7}	12 _{h6}	11.5	M5	11	40	69	1.15	50:1 100:1	5.4 7.8	5000	0.033	400	400	0.4 - 3 0.4 - 2	0.8 0.9

Anmerkungen:
Abmessungen und technische Daten des Motors: siehe Seite 2.
¹⁾Massenträgheitsmoment des Motors: siehe Seite 2.

Tooth-contour-backlash

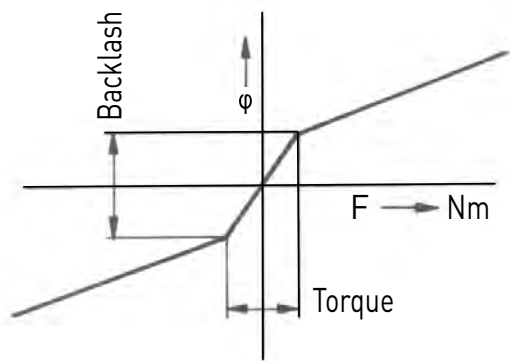

Resilient constant K

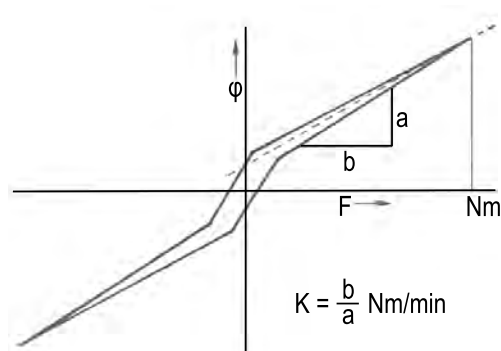

Industrial

Frequency Characteristics

The curves correspond to the limit values of the operational characteristics (M) as a function of the control pulses (frequency/speed), for two different supply voltages (U)

The motor connection type is 4-leads with parallel windings. The motors are controlled by phytron stepper motor power stages in the half-step mode.

Power Characteristics

For each frequency curve, the power characteristic (P) indicates the power delivered by the output shaft.

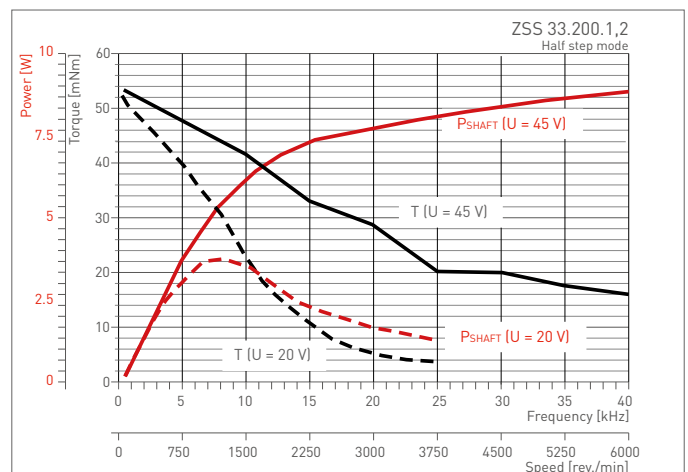
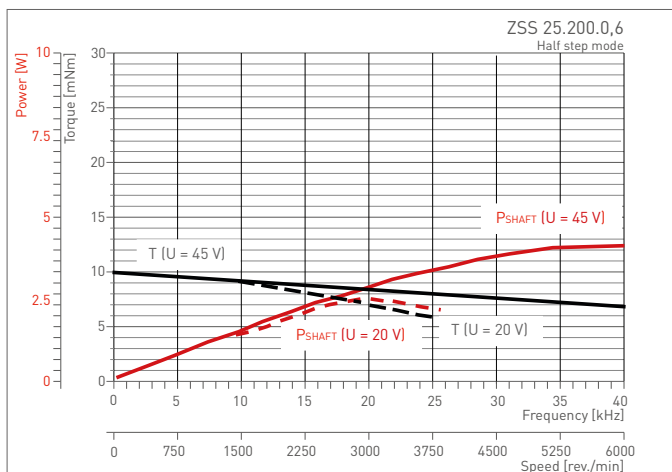
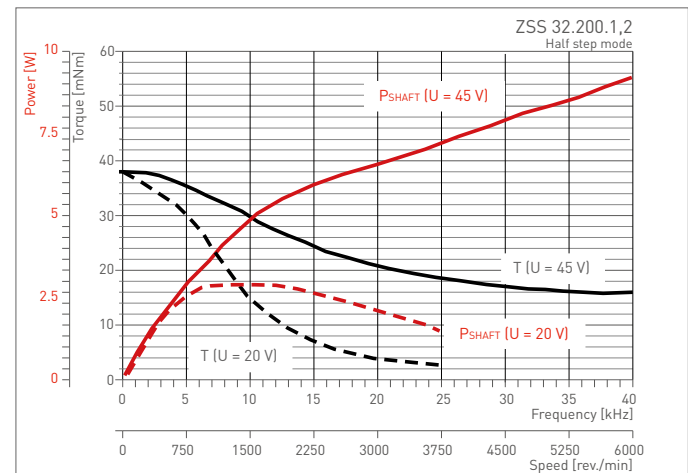
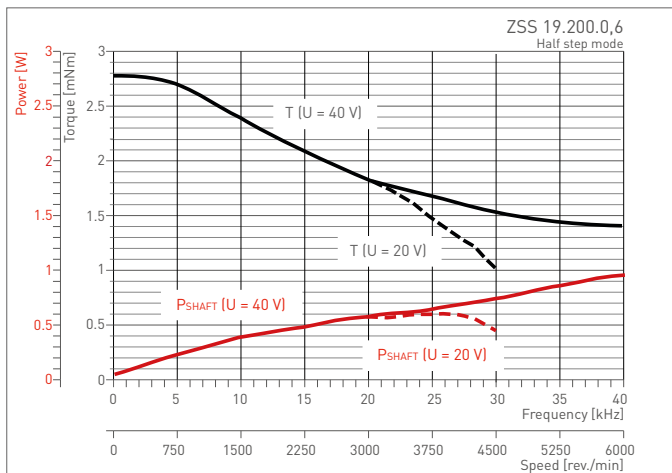
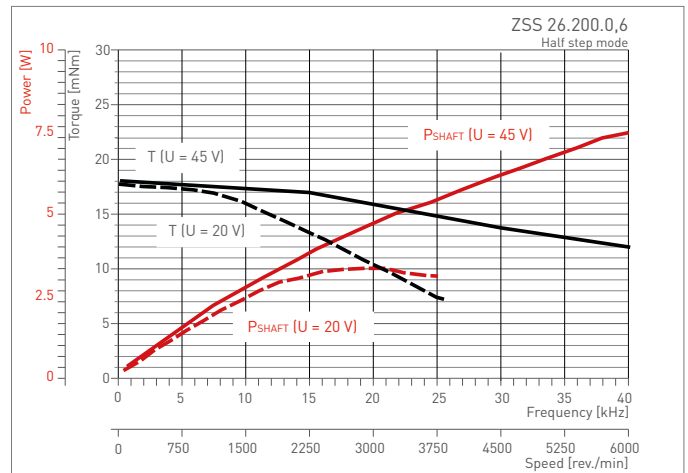

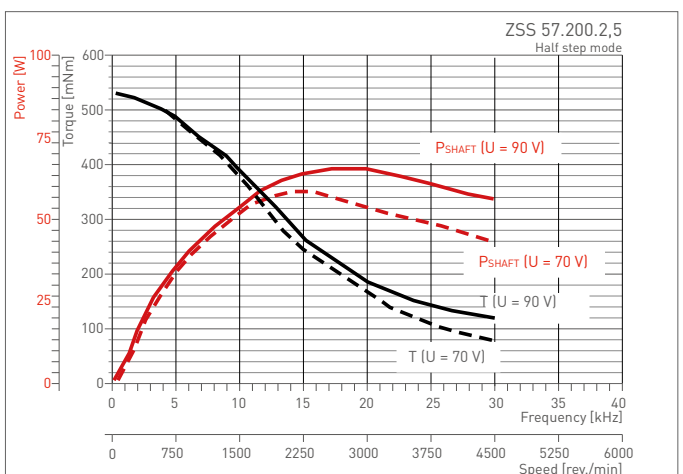
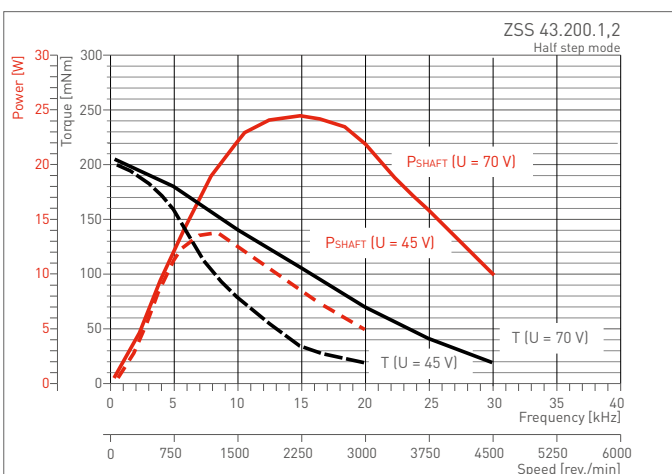
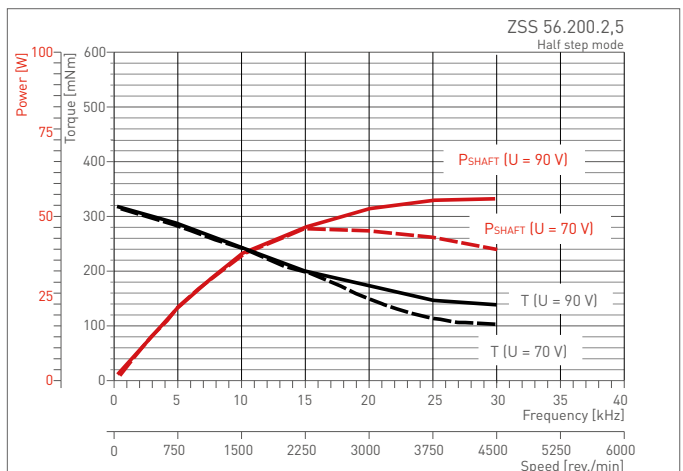
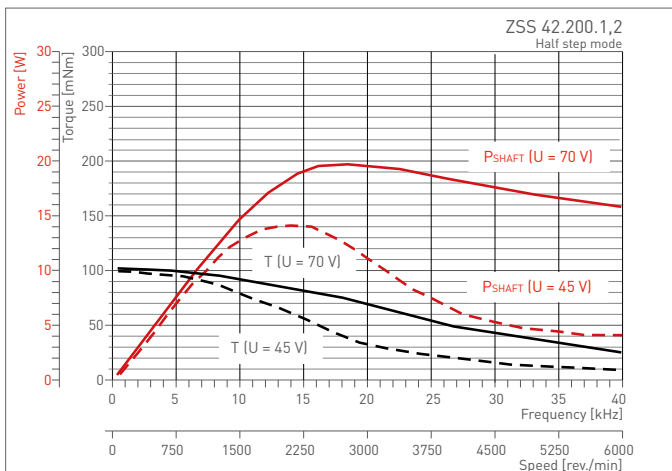
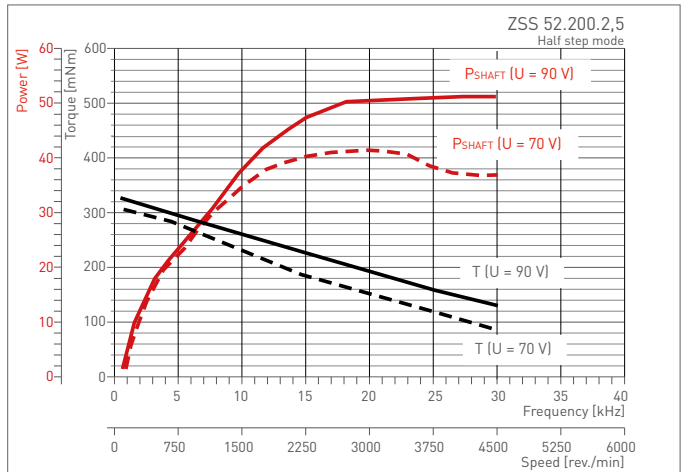
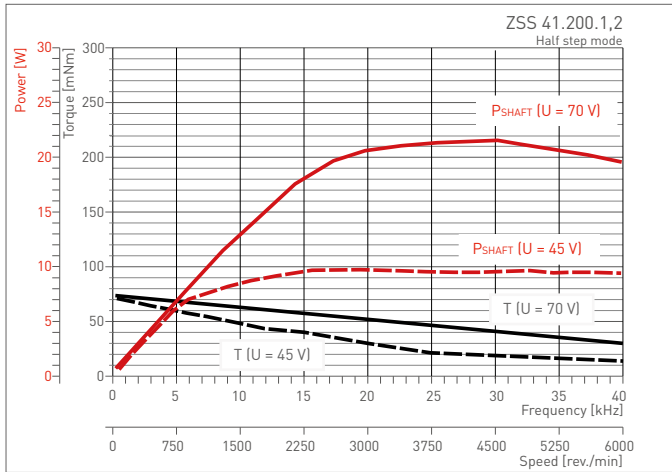

Industrial

Ordering Code

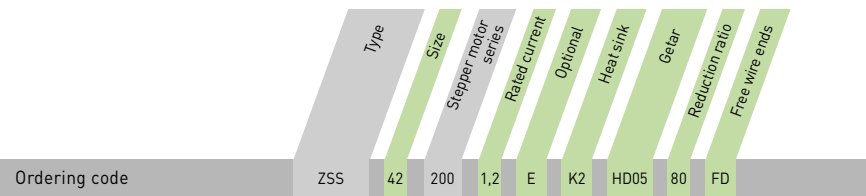

Options	
Size ¹⁾	19, 20, 25, 26, 32, 33, 41, 42, 43, 52, 56, 57
Rated current	0,6 ; 1,2 oder 2,5
Optional	2nd shaft (all types) E Encoder (ZSS 25 to 57) Motor brake (ZSS 32 to 57)
Heat sink	K1 or K2 for ZSS 19 to 57
Gear/reduction ratio	GPL: ZSS 19 to 57 PLG: ZSS 25 to 57 HD: ZSS 25 to 52 GSR: on request
Free wire ends	Optional: ZSS 41 to 57 Standard for ZSS 19 to 33

¹⁾ ZSS 52 to 57: with earthing screw

All illustrations, descriptions and technical specifications are subject to modifications; no responsibility is accepted for the accuracy of this information.

A motor connection leaflet is enclosed to every delivery of stepper motors. PDF files are available for download from the phytron homepage.

Phytron GmbH

Industriestraße 12 – 82194 Gröbenzell
 T +49-8142-503-0 F +49-8142-503-190