



# HIGH SPEED MOTORS

## MGV Series

Technical Manual

PVD 3627\_GB





## Compliance with « CE » directives

The high speed MGV motors Series complies with the Directive **2006/95/CE** and also meets the Standard IEC 60034-1.

Compliance with these standards requires high speed MGV motors to be mounted in accordance with the recommendations given in this user manual.

Equipment shall furthermore be mounted on a mechanical support that conducts heat effectively and does not exceed 40°C.

Start up date : Delivery date :
------------------------------------

**Parker**  
8, avenue du Lac – BP30749



## Table of Content

<b>1. INTRODUCTION.....</b>	<b>5</b>
1.1. PURPOSE AND INTENDED AUDIENCE.....	5
1.2. SAFETY.....	5
1.2.1. <i>Principle</i> .....	5
1.2.2. <i>General Safety Rules</i> .....	6
<b>2. PRODUCT DESCRIPTION.....</b>	<b>7</b>
2.1. OVERVIEW.....	7
2.2. MOTOR DESCRIPTION AND APPLICATIONS.....	8
2.2.1. <i>Test benches</i> .....	8
2.2.2. <i>Simulation benches</i> .....	8
2.3. GENERAL TECHNICAL DATA.....	9
2.4. PRODUCT CODE.....	10
<b>3. TECHNICAL DATAS.....</b>	<b>11</b>
3.1. MOTOR SELECTION.....	11
3.1.1. <i>Altitude derating</i> .....	11
3.1.2. <i>Temperature derating</i> .....	11
3.1.3. <i>Thermal equivalent torque (rms torque)</i> .....	13
3.1.4. <i>Acceleration – Deceleration time with MGV motors</i> .....	15
3.1.5. <i>Drive selection</i> .....	23
3.1.6. <i>Current limitation at stall conditions (i.e. speed &lt; 3 rpm)</i> .....	24
3.2. MOTOR CHARACTERISTICS AND DRIVE ASSOCIATION.....	25
3.2.1. <i>Intrinsic characteristics</i> .....	25
3.2.2. <i>DIGIVEX Drive Association</i> .....	25
3.2.3. <i>AC890 Drive Association</i> .....	26
3.2.4. <i>Illustration of tables</i> .....	26
3.2.5. <i>Further Data</i> .....	27
3.2.6. <i>Time constants of the motor</i> .....	28
3.2.7. <i>Voltage withstand characteristics of MGV series</i> .....	30
3.3. DIMENSION DRAWINGS.....	31
3.3.1. <i>General outline drawings</i> .....	31
3.4. MOTOR MOUNTING.....	32
3.4.1. <i>Motor mounting</i> .....	32
3.4.2. <i>Typical mounting</i> .....	32
3.4.3. <i>Frame recommendation</i> .....	33
3.4.4. <i>Motor alignment</i> .....	34
3.4.5. <i>Coupling</i> .....	35
3.4.6. <i>Pulley/belt</i> .....	35
3.4.7. <i>Vibration and bearings temperature control</i> .....	36
3.4.8. <i>Vibration resistance to shaft end</i> .....	36
3.5. BEARINGS.....	37
3.6. COOLING.....	38
3.6.1. <i>General recommendations</i> .....	38
3.6.2. <i>Additives for water as cooling media</i> .....	39
3.6.3. <i>Motor cooling circuit data</i> .....	40
3.6.4. <i>Chiller selection</i> .....	40

3.6.5.	<i>Flow derating according to glycol concentration</i> .....	41
3.6.6.	<i>Water cooling diagram</i> .....	43
3.7.	THERMAL PROTECTION .....	45
3.7.1.	<i>Alarm tripping with PTC thermistors</i> :.....	45
3.7.2.	<i>Temperature measurement with KTY sensors</i> :.....	46
3.8.	POWER ELECTRICAL CONNECTION .....	47
3.8.1.	<i>Wires sizes</i> .....	47
3.8.2.	<i>Conversion Awg/kcmil/mm<sup>2</sup></i> : .....	48
3.8.3.	<i>Motor cable length</i> .....	49
3.8.4.	<i>Ground connection</i> .....	49
3.8.5.	<i>Motor cable</i> .....	49
3.9.	FEEDBACK SYSTEM.....	50
3.9.1.	<i>Resolver</i> .....	50
3.9.2.	<i>Cables and connectors associated to the resolver</i> .....	51
3.9.3.	<i>Resolver setting</i> .....	51
3.9.4.	<i>Sin-Cos Encoder (on request)</i> .....	51
<b>4.</b>	<b>COMMISSIONING AND USE</b> .....	<b>52</b>
4.1.	RECEPTION, HANDLING, STORAGE .....	52
4.1.1.	<i>Equipment delivery</i> .....	52
4.1.2.	<i>Handling</i> .....	52
4.1.3.	<i>Storage</i> .....	53
4.2.	INSTALLATION.....	53
4.2.1.	<i>Mounting</i> .....	53
4.2.2.	<i>Preparation</i> .....	54
4.2.3.	<i>Mechanical assembly</i> .....	54
4.2.4.	<i>Alignment</i> .....	55
4.2.5.	<i>Motor startup</i> .....	57
4.2.6.	<i>Shaft line balancing and vibration control</i> .....	57
4.3.	ELECTRICAL CONNECTION .....	58
4.4.	MAINTENANCE OPERATIONS.....	59
4.5.	TROUBLESHOOTING .....	60

## 1. INTRODUCTION

### 1.1. Purpose and intended audience

This manual contains informations that must be observed to select, install, operate and maintain Parker MGV high speed Motors. The reader is expected to know the fundamentals of mechanical, electricity, wiring, electrical components and electrical schematic components.

Reading and understanding the information described in this document is mandatory before carrying out any operation on the motors. If any malfunction or technical problem occurs, that has not been dealt with in this manual, please contact Parker for technical assistance. In case of missing information or doubts regarding the installation procedures, safety instructions or any other issue tackled in this manual, please contact Parker as well.

Parker's responsibility is limited to the MGV motors and doesn't encompass the whole user's system. Data provided in this manual are for product description only and may not be guaranteed, unless expressly mentioned in a contract.



**DANGER:** Parker declines responsibility for any industrial accident or material damage that may arise, if the procedures and safety instructions described in this manual are not scrupulously followed.

### 1.2. Safety





#### 1.2.1. Principle

For this equipment to work safely, it must be transported, stored, handled, installed and serviced correctly. Following the safety instructions described in each section of this document is mandatory. High speed Motors usage must also comply with all applicable standards, national directives and factory instructions in force.



**DANGER:** Non-compliance with safety instructions, legal and technical regulations in force may lead to physical injuries or death, as well as damages to the property and the environment.

### 1.2.2. General Safety Rules

	<p><b>Generality</b>  <b>DANGER:</b> The installation, commissioning and operation must be performed by qualified personnel, in conjunction with this documentation.</p> <p>The qualified personnel must know the safety (C18510 authorization, standard VDE 0105 or IEC 0364) and local regulations.</p> <p>They must be authorized to install, commission and operate in accordance with established practices and standards.</p>
	<p><b>Electrical hazard</b></p> <p>Servo drives may contain non-insulated live AC or DC components. See the drives commissioning manual. Users are advised to guard against access to live parts before installing the equipment.</p> <p>The MGV requires special drives with flux weakening capabilities and all the safety features and equipment required for such usage. Check with the drive provider that the motor can be safely driven by its drive.</p> <p>Some parts of the motor or installation elements can be subject to dangerous voltages, especially when the motor is driven by the converter or when the motor rotor is manually rotated.</p> <p>Even after the electrical panel is de-energized, voltages may be present for more than 3 minutes until the power capacitors have had time to discharge. Use specified meter capable of measuring up to 1000V DC &amp; AC RMS to confirm that less than 50V is present between power terminals an earth. Check the drive recommendations.</p> <p>To prevent any accidental contact with live components, it is necessary to check that cables are not damaged, stripped or not in contact with a rotational part of the machine and to study first of all the following points:</p> <ul style="list-style-type: none"> <li>- Connector lug protection</li> <li>- Correctly fitted protection and earthing features</li> <li>- Workplace insulation (enclosure insulation humidity, etc.)</li> </ul> <p>General recommendations :</p> <ul style="list-style-type: none"> <li>- Check the bonding circuit</li> <li>- Lock the electrical cabinets</li> <li>- Use standardized equipment</li> </ul>
	<p><b>Mechanical hazard</b></p> <p>Servomotors can accelerate in milliseconds. Running the motor can lead to other sections of the machine moving dangerously. Moving parts must be screened off to prevent operators coming into contact with them or to protect the people against a shaft failure. The working procedure must allow the operator to keep well clear of the danger area.</p>
	<p><b>Burning Hazard</b></p> <p>Always bear in mind that some parts of the surface of the motor can reach temperatures exceeding 100°C.</p>

## 2. PRODUCT DESCRIPTION

### 2.1. Overview

The MGV high-speed motors from Parker are innovating solutions through direct drive, specifically designed for industrial applications where high speed is needed.

The MGV motors are brushless synchronous servomotors, with permanent magnets, based on HKW active parts and fully integrated with a water-cooled housing, high speed ball bearings, encoder ...

The water cooling increases the torque density and allows a silent operation.

These motors are taking advantage from the flux weakening principle that allows, at the same time, a high torque at low speed and a constant power after a given speed (called base speed).

As there is no current in the rotor, the losses in the rotor are very low

There are two areas :

- A constant torque area from the null speed to the base speed, where the motor is performing as an axis motor.
- A constant power area that allows to perform at higher speed.

**MGV motor typical curve**

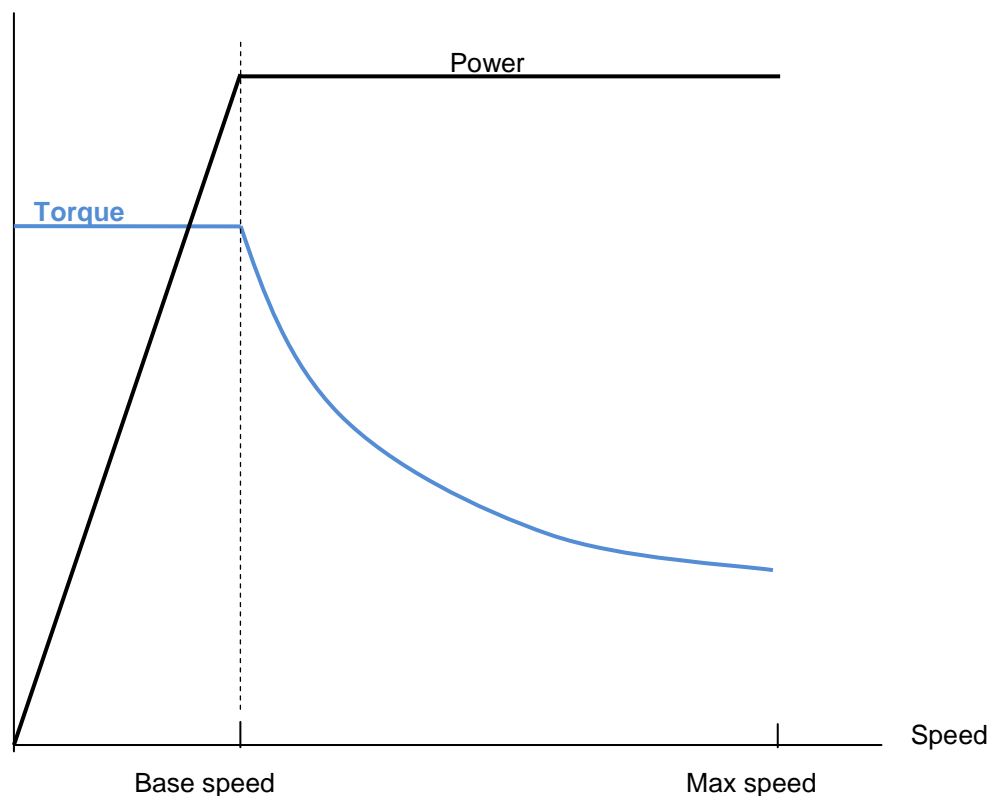

## 2.2. Motor description and Applications

These motors are characterized by a low inertia, a high acceleration capability and a high speed up ability.

Driving is insured through a 2 poles resolver giving an absolute position on one turn.

Many winding are available to get the wished torque and speed characteristics for power up to 80KW with the DIGIVEX drives.

Higher power is available with the universal PARKER AC890 drives.

The MGV motors are supplied integrated and ready to be used.

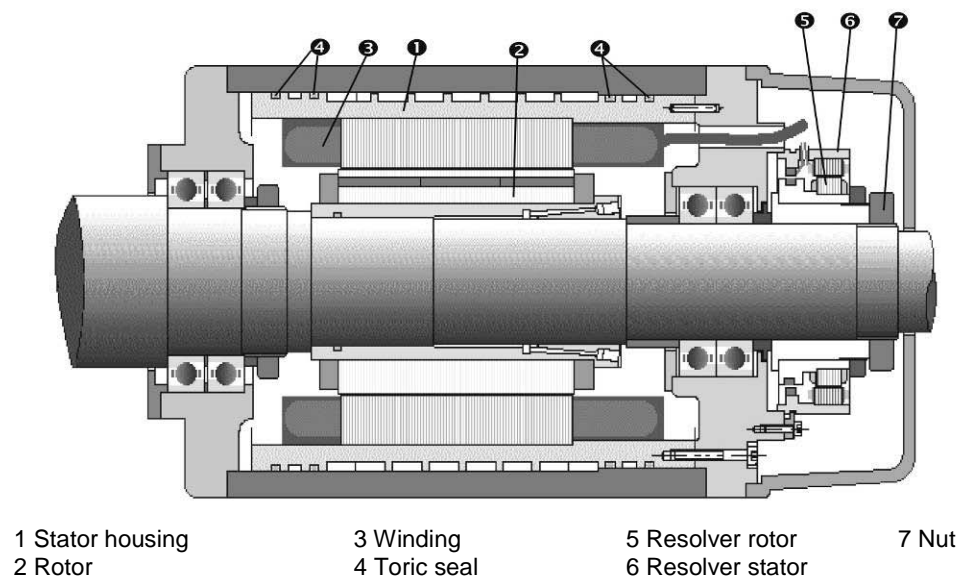

**Drawing 1 : Assembly example of an MGV motor**

### **2.2.1. Test benches**

MGV motors are successfully used on test benches for characterization, control, burn-in tests of automotive or aeronautical components (starters, pumps, alternators, pulleys, freewheels, belts, gearboxes ...).

### **2.2.2. Simulation benches**

Thanks to the possibility to generate running cycles with fast answers, the MGV motors can be used for simulation (speed simulation in urban cycle or automobile race, non-cyclic speed simulation for engine ...).



### 2.3. General technical data

<b>Motor type</b>	Permanent-magnet synchronous motor												
<b>Magnet material</b>	Nd-Fe-B												
<b>Number of poles</b>	<table border="1"> <tr> <td>Size:</td> <td>MGV400</td> <td>MGV600</td> <td>MGV800</td> <td>MGV900</td> <td>MGVA00</td> </tr> <tr> <td>Nbr of poles:</td> <td>4</td> <td>6</td> <td>6</td> <td>6</td> <td>8</td> </tr> </table>	Size:	MGV400	MGV600	MGV800	MGV900	MGVA00	Nbr of poles:	4	6	6	6	8
Size:	MGV400	MGV600	MGV800	MGV900	MGVA00								
Nbr of poles:	4	6	6	6	8								
<b>Mechanical interface</b>	Flange IM3001 (IM B5) or feet IM1001 (IM B3) (IEC60034-7)												
<b>Sizes</b>	4, 6, 8, 9, A												
<b>Degree of Protection</b>	IP40 as standard												
<b>Cooling</b>	Water cooled												
<b>Cooling water temperature</b>	5°C to 25°C (IEC 60034-1) – to avoid condensation see §3.6												
<b>Altitude</b>	Up to 1000m (IEC 60034-1) (for higher altitude see “Altitude derating”)												
<b>Rated voltage</b>	400 VAC or 480 VAC												
<b>Connections</b>	External power cables standard length 1.2m ; PTC probe, KTY84-130 sensor and encoder signal connector.												
<b>Insulation of the stator winding</b>	Class F according to IEC 60034-1 with potting												
<b>Thermal protection</b>	1 PTC probes and 1 KTY84-130 sensor												
<b>Operating temperature</b>	0°C...+40°C (IEC 60034-1) – to avoid condensation see §3.6												
<b>Storage temperature</b>	-20... +60°C												
<b>Rotor balancing</b>	G1 class												
<b>Shaft end</b>	Smooth shaft as standard												
<b>Bearings</b>	Steel or ceramic, depending on speed and load												
<b>Sensor</b>	Resolver												
<b>Paint finish</b>	Black RAL9005												
<b>Marking</b>	CE												



## 2.4. Product Code

Code	M	G	V	8	4	0	C	A	E	A	B	3	L	R	1	0	0	0
<b>Product Series</b>	_____			_____			_____			_____			_____			_____		
<b>Motor size</b> (in connection with diameter) 4, 6, 8, 9, or A	_____			_____			_____			_____			_____			_____		
<b>Active Part Length</b>	_____			_____			_____			_____			_____			_____		
<b>Torque / Speed characteristics</b> See motor datas	_____			_____			_____			_____			_____			_____		
<b>Feedback Sensor</b> A : Resolver K : sin/cos encoder (on request)	_____			_____			_____			_____			_____			_____		
<b>Mounting arrangement</b> B3 : by feet B5 : by flange	_____			_____			_____			_____			_____			_____		
<b>Bearing design</b> L : Low speed (common bearing) H : high speed (hybrid bearings) X : very high speed (X-Life bearings)	_____			_____			_____			_____			_____			_____		
<b>Unused character</b>	_____			_____			_____			_____			_____			_____		
<b>Mechanical Option</b> 1 : Cable connection 6 : terminal box (on request) 000 : Standard motor	_____			_____			_____			_____			_____			_____		

## 3. TECHNICAL DATAS

### 3.1. Motor selection

#### 3.1.1. Altitude derating

From 0 to 1000 m : no derating

From 1000 to 4000 m : torque derating of 5% for each step of 1000 m

#### 3.1.2. Temperature derating

##### Water cooled motor

Typical values are given with a water inlet temperature of 25°C and a temperature gradient Inlet-Outlet of 10°C. These references lead to a winding overheating of **90°C** corresponding to a winding temperature of **115°C**.

It is possible to increase a little bit the Inlet temperature up to 40°C, but the torque must be reduced. The following formula gives an indicative about the torque derating at low speed. But in any case refer to SSD Parker technical department to know the exact values

At low speed the torque derating is given by the following formula for an water Inlet temperature > 25°C.

$$\text{Torque\_derating}[\%] = 100 * \sqrt{\frac{(115^{\circ}\text{C} - \text{Inlet\_temperature}^{\circ}\text{C})}{90^{\circ}\text{C}}}$$



At high speed, the calculation is more complex, and the derating is much more important.

Please refer to PARKER to know the precise data of Torque derating according to water inlet temperature at high speed for a specific motor.

**N.B.** No general rules can be applied concerning the torque derating of MGV motors **at high speed**. Please refer to Parker for each case.

In fact, the torque derating at high speed also depends on :

- the flux weakening ratio which leads to a short circuit current inherent in the motor (no action can reduce its value),
- the maximal speed of the motor which determines the iron losses and mechanical losses due to the rotation.



Illustration of the torque derating vs. temperature at low speed for a MGV motor:

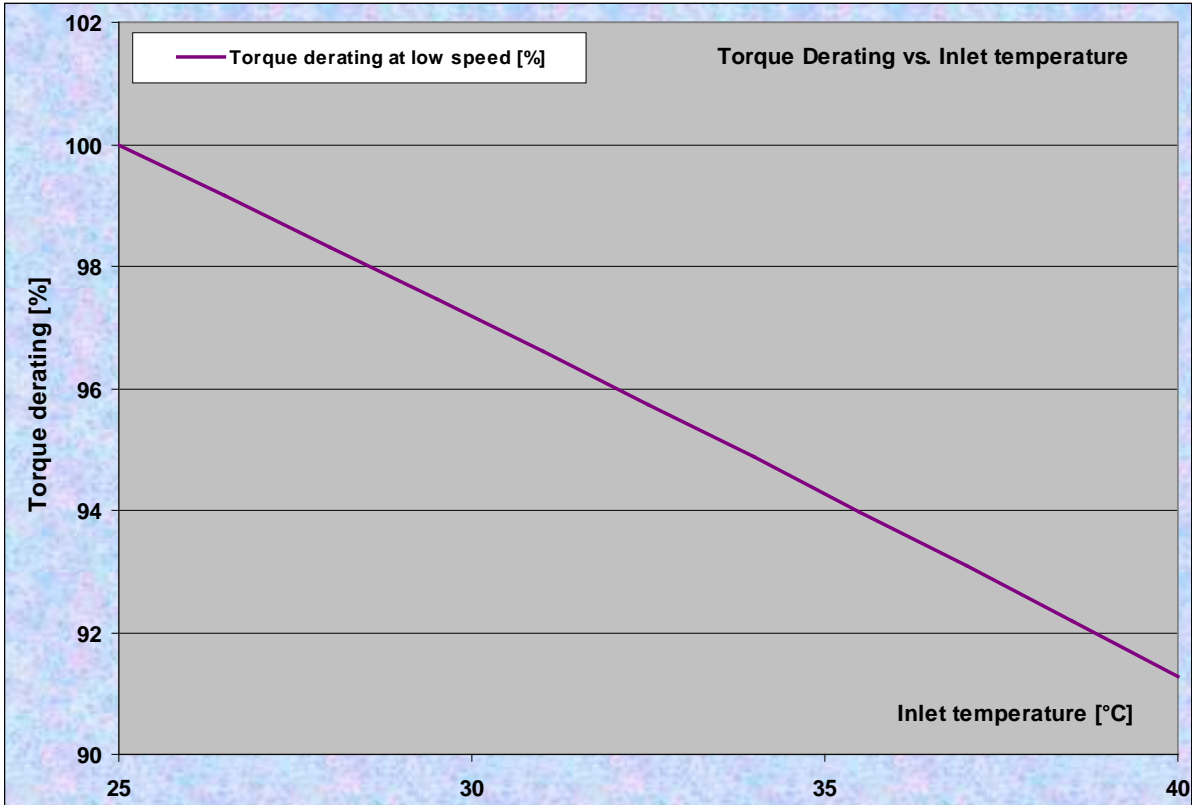

### 3.1.3. Thermal equivalent torque (rms torque)

The selection of the right motor can be made through the calculation of the rms torque  $M_{rms}$  (i.e. root mean squared torque) (sometimes called equivalent torque). This calculation does not take into account the thermal time constant. It can be used only if the overload time is much shorter than the copper thermal time constant. The rms torque  $M_{rms}$  reflects the heating of the motor during its duty cycle.

Let us consider:

- the period of the cycle  $T$  [s],
- the successively samples of movements  $i$  characterized each ones by the maximal torque  $M_i$  [Nm] reached during the duration  $\Delta t_i$  [s].

So, the rms torque  $M_{rms}$  can be calculated through the following basic formula:

$$M_{rms} = \sqrt{\frac{1}{T} * \sum_{i=1}^n M_i^2 \Delta t_i}$$

#### Example:

For a cycle of 2s at 0 Nm and 2s at 100Nm, the rms torque is

$$M_{rms} = \sqrt{\frac{1}{4} * 100^2 * 2} = 70,7 Nm$$

#### Illustration :

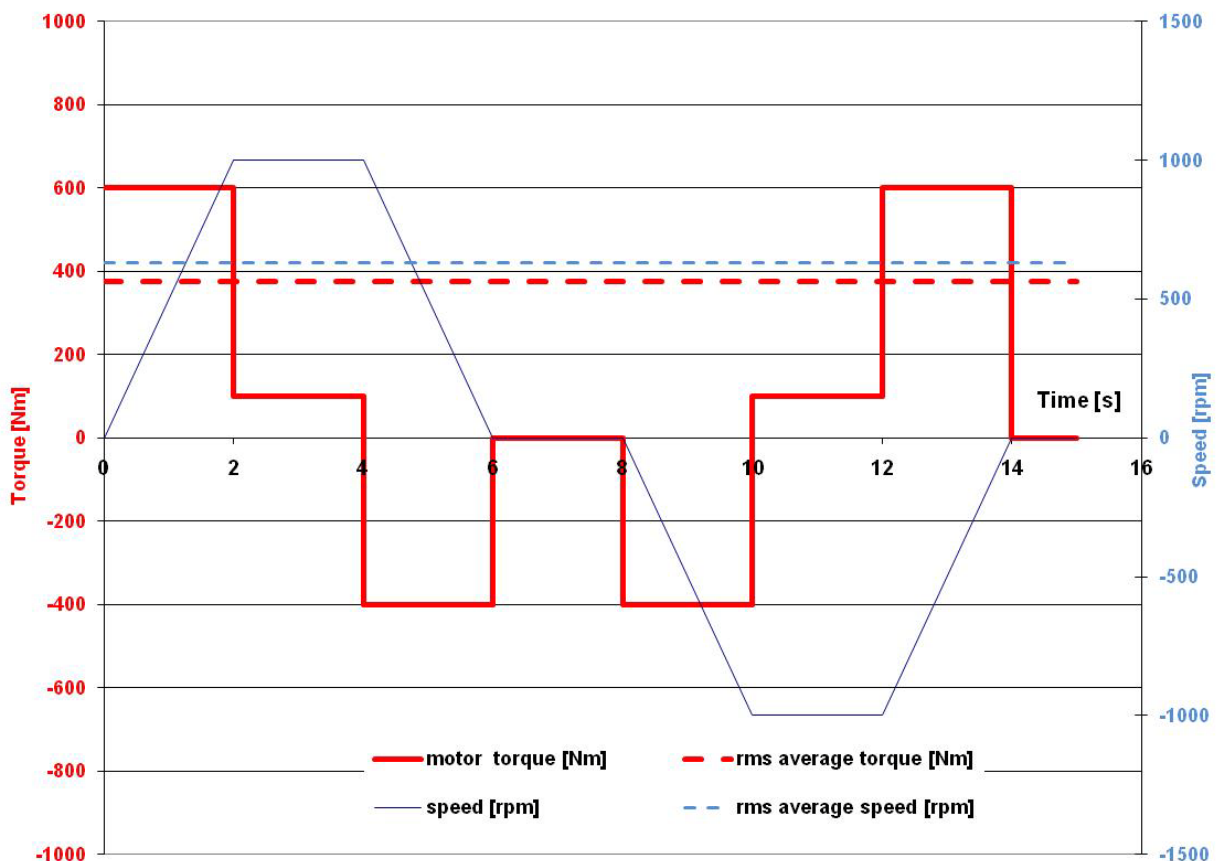

The maximal torque  $M_i$  delivered by the motor at each segment  $i$  of movement is obtained by the algebraic sum of the acceleration-deceleration torque and the resistant torque.

Therefore,  $M_{max}$  corresponds to the maximal value of  $M_i$ .

**Selection of the motor :**

The motor adapted to the duty cycle has to provide the rms torque  $M_{rms}$  at the rms speed(\*) without extra heating. This means that the permanent torque  $M_n$  available at the average speed presents a sufficient margin regarding the rms torque  $M_{rms}$ .

$$\Omega_{rms} = \sqrt{\frac{1}{T} * \sum_{i=1}^n \Omega_i^2 \Delta t_i}$$

(\*) rms speed is calculated thanks to the same formula as that used for the rms torque. The mean speed can not be used (in general mean speed is equal to zero). Only use the rms speed

Furthermore, each  $M_i$  and speed associated  $\Omega_i$  of the duty cycle has to be located in the operational area of the torque vs speed curve

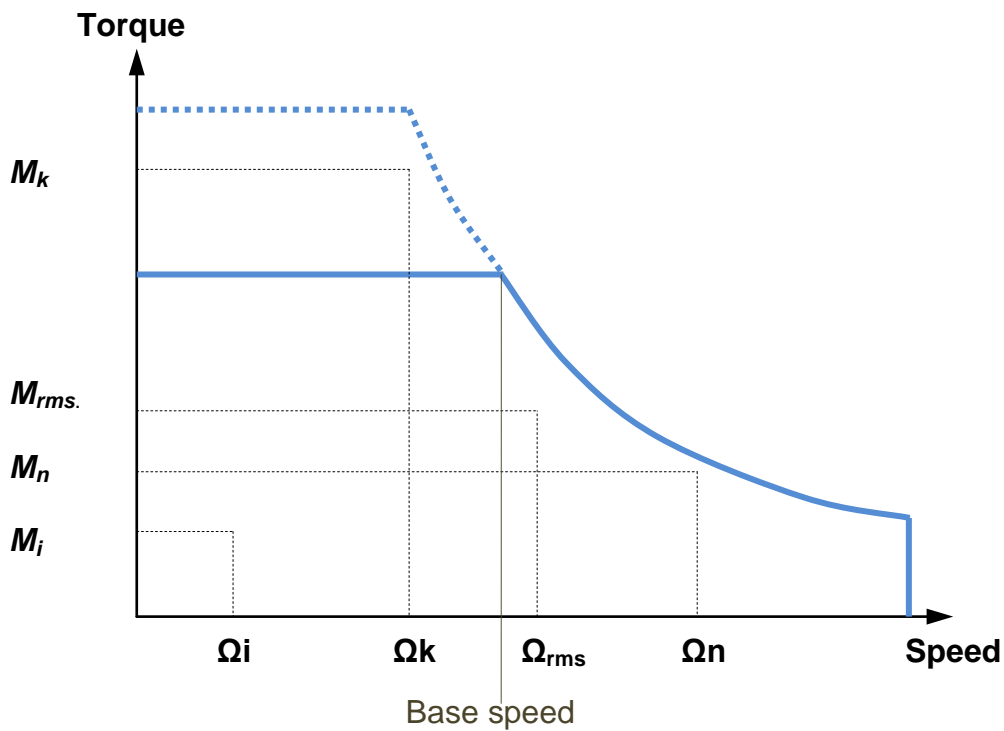

### 3.1.4. Acceleration – Deceleration time with MGV motors

A MGV motor shows two phases during its acceleration (resp. deceleration) time:

- from 0 to the *Base speed* during its acceleration (or inversely from the *Base speed* to 0 during its deceleration), the phase is called “at constant Torque”.
- from the *Base speed* to the *Maximal speed* during its acceleration (or inversely from the *Maximal speed* to the *Base speed* during its deceleration), the phase is called “at constant Power” or “Spindle mode”.

We assume that the resistant torque is maintained constant and that the motor is able to provide it during the whole acceleration (resp. deceleration) phase. So the calculation of the total acceleration (resp. deceleration) time can be separated in two parts as explained below. When the resistant torque is not constant, the calculation becomes more complex and can be made through iterative means.

#### Notations:

$N_{base}$	Base speed of the motor [rpm]
$\Omega_{base}$	Base angular speed of the motor [rad/s]
$\Sigma J$	Total inertia {motor rotor inertia + load inertia reflected to the motor} [kgm <sup>2</sup> ]
$M_{motor}$	equal to $M_{S6}$ (peak torque) for a short acceleration (deceleration) time, otherwise $M_{S1}$ (constant torque) [Nm]
$M_{resistant}$	Resistant torque, considered as constant during the whole acceleration (resp. deceleration) phase [Nm]
$M$	Torque available for the acceleration (respectively deceleration) [Nm]
$N_{max}$	Maximal speed of the application [rpm]
$\Omega_{max}$	Maximal angular speed of the application [rad/s]
$P_{motor}$	equal to $P_{S6}$ (peak power) for a short acceleration (deceleration) time, otherwise $P_{S1}$ (constant power) [W]
$P$	Power available for the acceleration (respectively deceleration) [W]
$t_1$	Acceleration (respectively deceleration) time “at constant Torque” [s]
$t_2$	Acceleration (respectively deceleration) time “at constant Power” [s]
$\Delta t$	Global acceleration (respectively deceleration) time [s]

#### Angular speeds:

$$\Omega_{base} = \frac{2 * \pi * N_{base}}{60} \quad \Omega_{max} = \frac{2 * \pi * N_{max}}{60}$$

#### 3.1.4.1. Constant Torque Phase – $t_1$ calculation

Acceleration time  $t_1$  “at constant Torque” from 0 to the *Base speed* :

$$M = M_{motor} - M_{resistant}$$

$$t_1 = \frac{\Omega_{base} * \Sigma J}{M}$$

Deceleration time  $t_1$  “at constant Torque” from *Base speed* to 0:

$$M = M_{motor} + M_{resistant}$$

$$t_1 = \frac{\Omega_{base} * \Sigma J}{M}$$

### 3.1.4.2. Constant Torque Phase – $t_2$ calculation

#### Method #1:

This method is simple and provides an estimation of  $t_2$  sufficient in most situations:

- when the resistant torque  $M_{resistant}$  is small compared to  $M_{motor}$
- when the resistant torque  $M_{resistant}$  is equal to 0.

#### Procedure to follow:

We calculate firstly an estimation of the resistant power  $P_{resistant}$  as follows:

$$P_{resistant} \approx M_{resistant} * \frac{(\Omega_{max} + \Omega_{base})}{2}$$

#### Acceleration time $t_2$ “at constant Power” from Base speed to Maximal speed:

The power available for the acceleration is equal to:

$$P = P_{mot} - P_{resistant}$$

So the estimated duration  $t_2$  is given by the formula:

$$t_2 = \frac{\frac{1}{2} \Sigma J * (\Omega_{max}^2 - \Omega_{base}^2)}{P}$$

#### Deceleration time $t_2$ “at constant Power” from Maximal speed to Base speed:

The power available for the deceleration is equal to:

$$P = P_{mot} + P_{resistant}$$

So the estimated duration  $t_2$  is given by the formula:

$$t_2 = \frac{\frac{1}{2} \Sigma J * (\Omega_{max}^2 - \Omega_{base}^2)}{P}$$

Total acceleration (resp. deceleration) time  $\Delta t$  will be given by the sum of  $t_1$  and  $t_2$ :

$$\Delta t = t_1 + t_2$$



Method #2:

This method is more complex but provides the exact solution for  $t_2$ . It is sometimes used where justified by the required accuracy or by a resistant torque  $M_{resistant}$  non-negligible compared to  $M_{motor}$ . This method is only valid if  $M_{resistant} \neq 0$ .

$t_2$  is solution of a nonlinear first order differential equation.

$M_{resistant} \neq 0$

Procedure to follow:

Acceleration time  $t_2$  "at constant Power" from Base speed to Maximal speed:

$$a = \Sigma J$$

$$b = P_{motor}$$

$$c = M_{resistant}$$

$$d = M_{motor} - M_{resistant}$$

$$y_0 = \Omega_{base}$$

$$y_1 = \Omega_{max}$$

$$\lambda = y_0 - \frac{b}{c}$$

$$\mu = \frac{a * \lambda}{c}$$

$$t_x = -\frac{1}{c} * Ln \left| \frac{1}{\lambda} * (y_1 - \frac{b}{c}) \right|$$

$$t_1 = \frac{y_0 * a}{d} \quad \text{acceleration\_time} \quad \text{in\_axis mode}$$

$$t_2 = \mu + \frac{a}{c} (b * t_x - \lambda * e^{-c * t_x}) \quad \text{acceleration\_time} \quad \text{in\_spindle mode}$$

Total acceleration time  $\Delta t$  from 0 to Maximal speed is given by the sum of  $t_1$  and  $t_2$ :

$$\Delta t = t_1 + t_2$$



Deceleration time  $t_2$  "at constant Power" from *Maximal speed* to *Base speed*:

$$a = \Sigma J$$

$$b = -P_{motor} \quad \text{negative value} \Leftrightarrow \text{braking}$$

$$c = M_{resistant}$$

$$d = -M_{motor} - M_{resistant}$$

$$y_0 = \Omega_{max}$$

$$y_1 = \Omega_{base}$$

$$\lambda = y_0 - \frac{b}{c}$$

$$\mu = \frac{a * \lambda}{c}$$

$$t_x = -\frac{1}{c} * Ln \left| \frac{1}{\lambda} * (y_1 - \frac{b}{c}) \right|$$

$$t_1 = -\frac{y_1 * a}{d} \quad \text{deceleration\_time in\_axis mode}$$

$$t_2 = \mu + \frac{a}{c} (b * t_x - \lambda * e^{-c * t_x}) \quad \text{deceleration\_time in\_spindle mode}$$

Total deceleration time  $\Delta t$  from *Max speed* to 0 will be given by the sum of  $t_1$  and  $t_2$ :

$$\Delta t = t_1 + t_2$$

### 3.1.4.3. Numerical example:

The MGVS motor taken to illustrate the calculations is the type **MGV840CAD**

Corresponding data are as follows:

$$P_{S1} = P_{S6} = 63 \text{ kW}$$

$$N_{base} = 10300 \text{ rpm}$$

$$N_{max} = 24000 \text{ rpm}$$

$$M_{S1} = 58.4 \text{ Nm}$$

$$M_{S6} = 93.5 \text{ Nm}$$

$$J_{motor} = 0.01455 \text{ kgm}^2$$

We will consider:

$$M_{resistant} = 6 \text{ Nm}$$

$$J_{load} = J_{motor} = 0.01455 \text{ kgm}^2$$

#### Method #1

$$\Omega_{base} = \frac{2 * \pi * N_{base}}{60} = \frac{2 * \pi * 10300}{60} = 1079 \text{ rad/s}$$

$$\Omega_{max} = \frac{2 * \pi * N_{max}}{60} = \frac{2 * \pi * 24000}{60} = 2513 \text{ rad/s}$$

$$\Sigma J = J_{motor} + J_{load} = 0.01455 + 0.001455 = 0.02910 \text{ kgm}^2$$

$$P_{resistant} \approx M_{resistant} * \frac{(\Omega_{max} + \Omega_{base})}{2} = 6 * \frac{(2513 + 1079)}{2} = 10776 \text{ W}$$

Acceleration duration  $t_1$  "at constant Torque" from 0 to the Base speed :

$$M = M_{motor} - M_{resistant} = 58.4 - 6 = 52.4 \text{ Nm}$$

$$t_1 = \frac{\Omega_{base} * \Sigma J}{M} = \frac{1079 * 0.02910}{52.4} = 0.599 \text{ s}$$

Deceleration time  $t_1$  "at constant Torque" from the Base speed to 0:

$$M = M_{motor} + M_{resistant} = 58.4 + 6 = 64.4 \text{ Nm}$$

$$t_1 = \frac{\Omega_{base} * \Sigma J}{M} = \frac{1079 * 0.02910}{64.4} = 0.487 \text{ s}$$

Acceleration time  $t_2$  "at constant Power" from Base speed to Maximal speed:

The power available for the acceleration is equal to:

$$P = P_{mot} - P_{resistant} = 63000 - 10776 = 52224 \text{ W}$$

So the estimated duration  $t_2$  is given by the formula:

$$t_2 = \frac{1}{2} \frac{\Sigma J (\Omega_{max}^2 - \Omega_{base}^2)}{P} = \frac{0.5 * 0.02910 * (2513^2 - 1079^2)}{52224} = 1.436 \text{ s}$$

Total acceleration time  $\Delta t$  from 0 to Maximal speed is given by the sum of  $t_1$  and  $t_2$ :

$$\Delta t = t_1 + t_2 = 0.599 + 1.436 = 2.035 \text{ s}$$



Deceleration time  $t_2$  "at constant Power" from Maximal speed to Base speed:

The power available for the deceleration is equal to:

$$P = P_{mot} + P_{resistant} = 63000 + 10776 = 73776 \quad W$$

So the estimated duration  $t_2$  is given by the formula:

$$t_2 = \frac{\frac{1}{2} \Sigma J (\Omega_{max}^2 - \Omega_{base}^2)}{P} = \frac{0.5 * 0.02910 * (2513^2 - 1079^2)}{73776} = 1.016 \quad s$$

Total deceleration time  $\Delta t$  from Max speed to 0 will be given by the sum of  $t_1$  and  $t_2$ :

$$\Delta t = t_1 + t_2 = 0.487 + 1.016 = 1.503 \quad s$$

## Method #2

$t_2$  is solution of a nonlinear first order differential equation.

$M_{resistant} \neq 0$

Acceleration time  $t_2$  "at constant Power" from Base speed to Maximal speed:

$$a = \Sigma J = J_{motor} + J_{load} = 0.02910 \quad \text{kgm}^2$$

$$b = P_{mot} = 63000 \quad W$$

$$c = M_{resistant} = 6 \quad Nm$$

$$d = M_{mot} - M_{resistant} = M = 58.4 - 6 = 52.4 \quad Nm$$

$$y_0 = \Omega_{base} = 1079 \quad \text{rad} / s$$

$$y_1 = \Omega_{max} = 2513 \quad \text{rad} / s$$

$$\lambda = y_0 - \frac{b}{c} = 1079 - \frac{63000}{6} = -9421$$

$$\mu = \frac{a * \lambda}{c} = \frac{0.02910 * (-9421)}{6} = -45.69$$

$$t_x = -\frac{1}{c} * \text{Ln} \left| \frac{1}{\lambda} * (y_1 - \frac{b}{c}) \right| = -\frac{1}{6} * \text{Ln} \left| \frac{1}{-9421} * (2513 - \frac{63000}{6}) \right| = 0.0275$$

$$t_1 = \frac{y_0 * a}{d} = \frac{1079 * 0.02910}{52.4} = 0.599 \text{ s} \quad \text{acceleration\_axis mode}$$

$$t_2 = \mu + \frac{a}{c} (b * t_x - \lambda * e^{-c * t_x}) \quad \text{acceleration\_spindle mode}$$

$$t_2 = -45.69 + \frac{0.02910}{6} (63000 * 0.0275 - (-9421) * e^{-6 * 0.0275}) = 1.455 \text{ s}$$

Total acceleration time  $\Delta t$  from 0 to Maximal speed is given by the sum of  $t_1$  and  $t_2$ :

$$\Delta t = t_1 + t_2 = 0.599 + 1.455 = 2.054 \text{ s}$$



Deceleration time  $t_2$  “at constant Power” from *Maximal speed* to *Base speed*:

$$a = \Sigma J = J_{motor} + J_{load} = 0.02910 \quad \text{kgm}^2$$

$$b = -P_{mot} = -63000 \quad \text{W} \quad \text{negative value} \Leftrightarrow \text{braking}$$

$$c = M_{resistant} = 6 \quad \text{Nm}$$

$$d = -M_{mot} - M_{resistant} = M = -58.4 - 6 = -64.4 \quad \text{Nm} \quad \text{negative value} \Leftrightarrow \text{braking}$$

$$y_0 = \Omega_{max} = 2513 \quad \text{rad / s}$$

$$y_1 = \Omega_{base} = 1079 \quad \text{rad / s}$$

$$\lambda = y_0 - \frac{b}{c} = 2513 - \frac{-63000}{6} = 13013$$

$$\mu = \frac{a * \lambda}{c} = \frac{0.02910 * 13013}{6} = 63.114$$

$$t_x = -\frac{1}{c} * \text{Ln} \left| \frac{1}{\lambda} * (y_1 - \frac{b}{c}) \right| = -\frac{1}{6} * \text{Ln} \left| \frac{1}{13013} * (1079 - \frac{-63000}{6}) \right| = 0.01947$$

$$t_1 = -\frac{y_1 * a}{d} = -\frac{1079 * 0.02910}{-64.4} = 0.487 \text{ s} \quad \text{deceleration\_time} \quad \text{in\_axis mode}$$

$$t_2 = \mu + \frac{a}{c} (b * t_x - \lambda * e^{-c * t_x}) \quad \text{deceleration\_time} \quad \text{in\_spindle mode}$$

$$t_2 = 63.114 + \frac{0.02910}{6} (-63000 * 0.01947 - 13013 * e^{-6 * 0.01947}) = 1.0095 \quad \text{s}$$

Total deceleration time  $\Delta t$  from *Max speed* to 0 will be given by the sum of  $t_1$  and  $t_2$ :

$$\Delta t = t_1 + t_2 = 0.487 + 1.0095 = 1.497 \quad \text{s}$$

Illustrations:

Acceleration phase

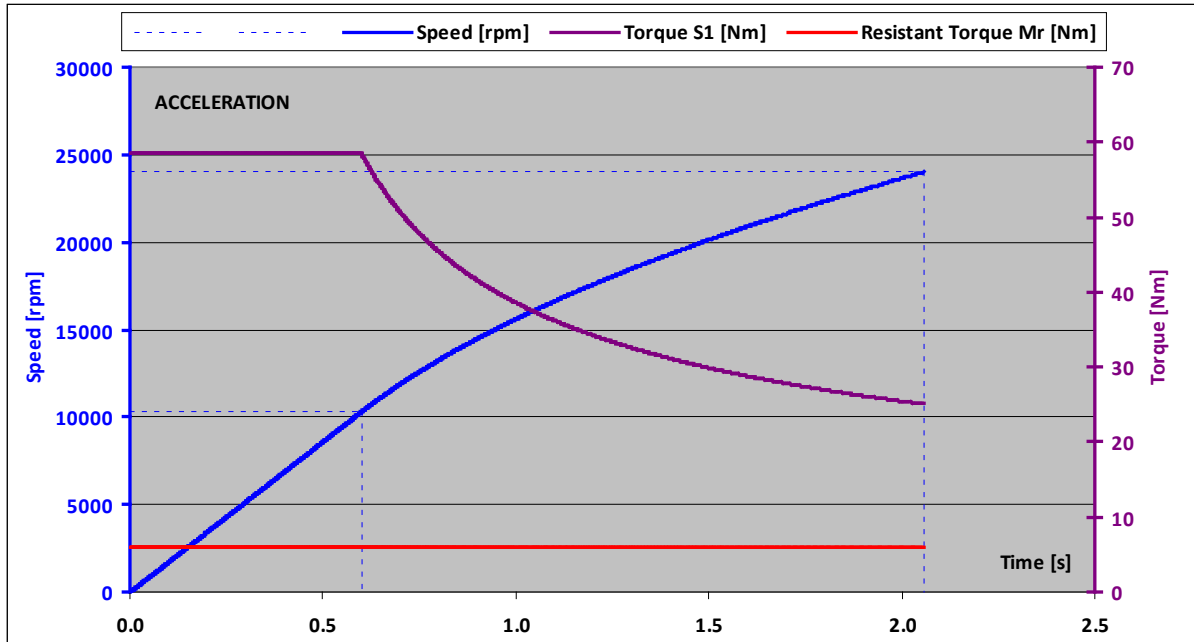



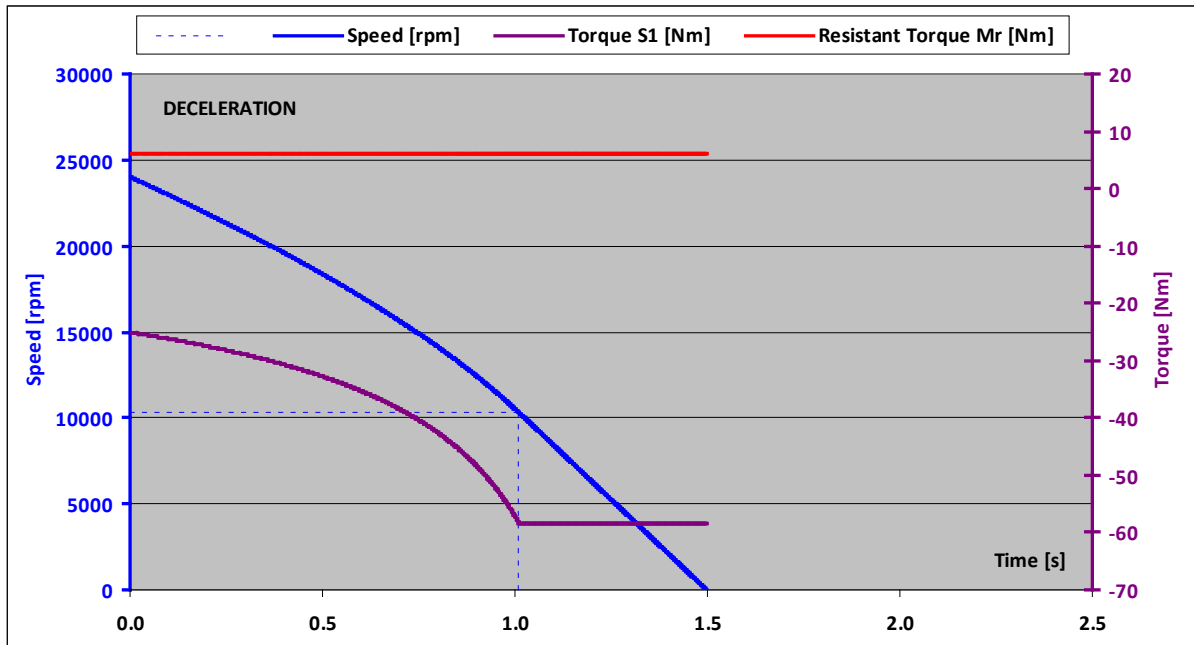



Deceleration phase



### 3.1.5. Drive selection

The drive selection depends on its rated power, nominal current and maximal electrical frequency able to be managed by the drive and by the flux weakening ratio.

	<p>Please refer to the drive technical documentation for any further information and to select the best motor and drive association.</p>
	<p>Short circuit current of the motor must be lower than the permanent current of the drive</p> $I_{cc\_motor} < I_{S1\_drive}$ <p>Please refer to the drive technical documentation</p>
	<p>Short circuit current of the motor must be lower than 0.8 times the peak current of the drive</p> $I_{cc\_motor} < 0.8 \times I_{peak\_drive}$ <p>Please refer to the drive technical documentation</p>
	<p>Max back emf of the motor must be lower than the max voltage (from the motor) supported by the drive</p> <p>Please refer to the drive technical documentation</p>
	<p>The drive must be able to manage the flux weakening and must avoid voltage higher than the nominal motor voltage at the motor terminals. Please, check field weakening ratio supported by the drive.</p> <p>Field weakening ratio = Max speed divided by the basis speed</p>
	<p>Due to the maximum electrical frequency able to be managed by the drive, the motor has a speed limitation given as follows:</p> $\text{Speed limitation (rpm)} = \frac{2 * \text{Max\_drive\_frequency (Hz)} * 60}{\text{Number\_of\_poles}}$
	<p>Other limitations can come from the bearing type (steel straight, hybrid or Xlife)</p> <p>Cf: §3.4 Bearing</p>

### 3.1.6. Current limitation at stall conditions (i.e. speed < 3 rpm)

Recommended reduced current at speed < 3 rpm:

$$I_{reduced} = \frac{1}{\sqrt{2}} * I_0 \cong 0.7 * I_0$$



**Warning:** The current must be limited to the prescribed values. If the nominal torque has to be maintained at stop or low speed (< 3 rpm), imperatively limit the current to 70% of  $I_0$  (permanent current at low speed), in order to avoid an excessive overheating of the motor.



Please refer to the drive technical documentation for any further information and to choose functions to program the drive.



## 3.2. Motor characteristics and drive association

### 3.2.1. Intrinsic characteristics

Motor	Electronic Drive	S1 Power	S6 power	Low speed torque S1	Low speed S6 torque	Base speed	Max speed	Bearings	Permanent current at low speed	S6 current at low speed
		PS1 (kW)	PS6 (kW)	Mo (Nm)	MoS6 (Nm)	Nb (rpm)	N (rpm)		Io (Arms)	Io S6 (Arms)
MGV430BAL	DRIVE 25/51 - 400	10	10	7,3	11	13100	45000	X life	24,7	50,2
MGV430BAI	DRIVE 35/79 - 400	15,6	15,6	6,8	11	21900	45000	X life	35,0	78,1
MGV635CAF	DRIVE 37/57 - 400	15,6	15,6	20	30	7450	30000	X life	36,6	56,1
MGV635CAD	DRIVE 55/85 - 400	25	25	20	30	11900	30000	X life	54,8	84,2
MGV840CAP	DRIVE 37/57 - 400	16	16	68	100	2250	24000	X life	36,3	56,7
MGV840CAH	DRIVE 73/114 - 400	32	32	68	100	4500	24000	X life	72,6	113,0
MGV840CAF	DRIVE 94/151 - 400	44	44	66	100	6370	24000	X life	93,8	151,0
MGV840CAD	DRIVE 123/227 - 400	63	63	58	100	10300	24000	X life	123,0	227,0
MGV950CAC	DRIVE 222/456 - 400	105	105	200	300	5010	20000	X life	252,0	456,0
MGV950CAX	DRIVE 454/821 - 400	175	175	200	300	8350	20000	X life	454,0	821,0
MGV970CBX	DRIVE 542/661 - 400	230	230	390	490	5630	12000	Hybrid	542	754,0
MGVA50DAC	DRIVE 154/191 - 400	67	67	480	600	1330	12000	Hybrid	154,0	199,0
MGVA50DAB	DRIVE 230/287 - 400	101	101	480	600	2010	12000	Hybrid	230,0	299,0
MGVA50DAA	DRIVE 439/598 - 400	200	200	460	600	4150	12000	Hybrid	439,0	598,0
MGVA50DBB	DRIVE 470/660 - 400	195	220	620	800	3000	12000	Hybrid	465,2	653,0

### 3.2.2. DIGIVEX Drive Association

Motor	Electronic Drive	S1 Power	S6 power	Low speed torque S1	Low speed S6 torque	Base speed	Max speed	Bearings
		PS1 (kW)	PS6 (kW)	Mo (Nm)	MoS6 (Nm)	Nb (rpm)	N (rpm)	
MGV430BAL	DIGIVEX 32/64	9,7	9,7	6,9	6,9	13000	45000	X life
MGV430BAI	DIGIVEX 50/80	16	16	6,8	6,9	22000	45000	X life
MGV635CAF	DIGIVEX 50/80	16	16	19	19	7600	30000	X life
MGV635CAD	DIGIVEX 100/120	25	25	20	26	12000	30000	X life
MGV840CAP	DIGIVEX 50/80	16	16	66	66	2300	24000	X life
MGV840CAH	DIGIVEX 100/120	32	32	66	66	4600	24000	X life
MGV840CAF	DIGIVEX 150	44	44	66	74	6400	24000	X life
MGV840CAD	DIGIVEX 300	63	63	58	95	10000	24000	X life
MGVA50DAC	DIGIVEX 300	67	67	480	600	1300	12000	Hybrid

### 3.2.3. AC890 Drive Association

Motor	Electronic Drive	S1 Power	S6 power	Low speed torque S1	Low speed S6 torque	Base speed	Max speed	Bearings
		PS1 (kW)	PS6 (kW)	Mo (Nm)	MoS6 (Nm)	Nb (rpm)	N (rpm)	
MGV430BAL	890SD-53230SC	10	10	7,3	8,4	13000	27900	Hybrid
MGV430BAI	890SD-532450D	16	16	6,8	7,3	22000	30000	Hybrid
MGV635CAF	890SD-532450D	16	16	20	21	7500	15800	Steel
MGV635CAD	890SD-532590D	24	24	18	18	13000	20000	Hybrid
MGV635CAD	890SD-432730E	25	25	20	27	12000	16000	Steel
MGV840CAP	890SD-532450D	16	16	68	71	2300	4510	Steel
MGV840CAH	890SD-432870E	32	32	68	83	4500	9010	Steel
MGV840CAF	890SD-433105F	44	44	66	86	6400	12000	Steel
MGV840CAD	890SD-433145F	63	63	58	67	10000	16000	Hybrid
MGV950CAC	890SD-433316G	110	110	200	220	5000	10200	Steel
MGV950CAX	890SD-433420H	160	160	170	170	8900	16000	Hybrid
MGV950CAX	890SD-433520H	180	180	200	200	8400	16000	Hybrid
MGV970CBX	890SD-433520H	220	220	350	350	6000	10900	X life
MGVA50DAC	890SD-433145F	66	66	450	450	1400	2500	Steel
MGVA50DAB	890SD-433250G	100	100	480	490	2000	3750	Steel
MGVA50DAA	890SD-433520H	200	200	460	490	4200	7510	Steel
MGVA50DBB	890SD-433520H	200	200	620	620	3000	5780	Steel

### 3.2.4. Illustration of tables

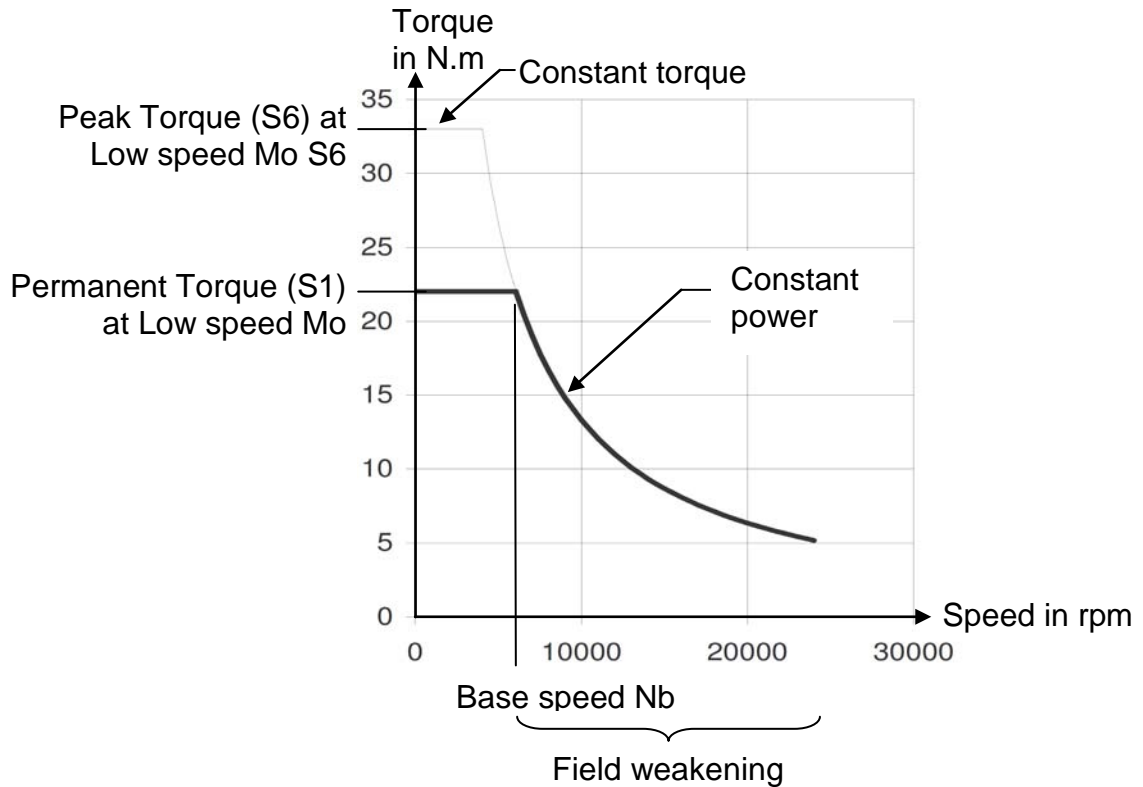

### 3.2.5. Further Data

Motor	Winding resistance line-line (25°C)	Rotor inertia	Thermal time constant	Motor mass	Back emf constant at 1000 rpm	Winding quadrature inductance line-line	Winding direct inductance line-line	Number of poles	Short-circuit current
	Rb (Ohms)	J (kg.m <sup>2</sup> )	Tth (min)	M (kg)	Ke (Vrms)	Lq (mH)	Ld (mH)	-	Icc (Arms)
MGV430BAL	0,541	0,00089	1	35	18,3	5,68	4,96	4	20,3
MGV430BAI	0,205	0,00089	1	35	11,7	2,35	2,05	4	31,6
MGV635CAF	0,427	0,00352	1,5	50	32,2	4,35	3,82	6	31
MGV635CAD	0,189	0,00352	1,5	50	21,5	1,93	1,7	6	46,5
MGV840CAP	0,823	0,0186	2,4	100	113	15,4	12,8	6	32,5
MGV840CAH	0,209	0,0186	2,4	100	56,6	3,84	3,2	6	65
MGV840CAF	0,117	0,0186	2,4	100	42,4	2,16	1,8	6	87
MGV840CAD	0,0522	0,0186	2,4	100	28,3	0,96	0,8	6	130
MGV950CAC	0,0239	0,063	3,2	250	50,1	0,954	0,9	6	204
MGV950CAX	0,00747	0,063	3,2	250	27,8	0,294	0,278	6	368
MGV970CBX	0,00963	0,0866	3	270	47	0,35	0,368	6	470
MGVA50DAC	0,141	0,292	4	400	204	4,36	4,32	8	130
MGVA50DAB	0,063	0,292	4	400	136	1,94	1,92	8	195
MGVA50DAA	0,0157	0,292	4	400	67,9	0,484	0,48	8	390
MGVA50DBB	0,0166	0,292	4	400	88,2	0,548	0,551	8	441

### 3.2.6. Time constants of the motor

#### 3.2.6.1. Electric time constant:

$$\tau_{elec} = \frac{L_{ph\_ph}}{R_{ph\_ph}}$$

With following values given in the motor data sheet

$L_{ph\_ph}$  inductance of the motor phase to phase [H],

$R_{ph\_ph}$  resistance of the motor phase to phase at 25°C [Ohm].

#### Example:

Motor series MGV840CAP

$L_{ph\_ph} = 15.4$  mH or  $15.4E-3$  H

$R_{ph\_ph}$  at 25°C = 0.823 Ohm

→  $\tau_{elec} = 15.4E-3/0.823 = 18.7$  ms

An overall summary of motor time constants is given a little further.

#### 3.2.6.2. Mechanical time constant:

$$\tau_{mech} = \frac{R_{ph\_ph} * J}{Kt * Ke_{ph\_ph}} = \frac{0.5 * R_{ph\_ph} * J}{(3 * \frac{Ke_{ph\_ph}}{\sqrt{3}}) * \frac{Ke_{ph\_ph}}{\sqrt{3}}}$$

$$\tau_{mech} = \frac{0.5 * R_{ph\_ph} * J}{(Ke_{ph\_ph})^2}$$

With following values obtained from the motor data sheet:

$R_{ph\_ph}$  resistance of the motor phase to phase at 25°C [Ohm],

$J$  inertia of the rotor [kgm<sup>2</sup>],

$Ke_{ph\_ph}$  back emf phase coefficient phase to phase [V<sub>rms</sub>/rad/s].

The coefficient  $Ke_{ph\_ph}$  in the formula above is given in [V<sub>rms</sub>/rad/s]

To calculate this coefficient from the datasheet, use the following relation:

$$Ke_{ph\_ph[V_{rms}/rad/s]} = \frac{Ke_{ph\_ph[V_{rms}/1000rpm]}}{\frac{2 * \pi * 1000}{60}}$$

#### Example:

Motor series MGV840CAP

$R_{ph\_ph}$  at 25°C = 0.823 Ohm

$J = 0.0186$  kgm<sup>2</sup>

$Ke_{ph\_ph} [V_{rms}/1000rpm] = 113$  [V<sub>rms</sub>/1000rpm]

→  $Ke_{ph\_ph} [V_{rms}/rad/s] = 113/(2 * \pi * 1000/60) = 1.079$  [V<sub>rms</sub>/rad/s]

→  $\tau_{mech} = 0.5 * 0.823 * 0.0186 / (1.079^2) = 6.5$  ms

**Remarks:**

For a DC motor, the mechanical time constant  $\sigma_{mech}$  represents the duration needed to reach 63% of the final speed when applying a voltage step without any resistant torque, if the electrical time constant is much smaller than the mechanical time constant.

An overall summary of motor time constants is given a little further.

**3.2.6.3. Thermal time constant of the copper:**

$$\tau_{therm} = Rth_{copper\_iron} * Cth_{copper}$$

$$Cth_{copper[J/^{\circ}K]} = Mass_{copper[Kg]} * 389_{[J/kg^{\circ}K]}$$

With:

**$Rth_{copper\_iron}$**  thermal resistance between copper and iron [ $^{\circ}K/W$ ]

**$Cth_{copper}$**  thermal capacity of the copper [ $J/^{\circ}K$ ]

**$Mass_{copper}$**  mass of the copper (winding) [kg]

Hereunder is given an overall summary of motor time constants:

Type	Electric time constant [ms]	Mechanical time constant [ms]	Thermal time constant of copper [s]
MGV430B	11,5	7,3	23
MGV635C	10,2	8,0	34
MGV840C	18,7	6,5	42
MGV950C	39,9	3,3	45
MGVA50D	30,9	5,5	55

### 3.2.7. Voltage withstand characteristics of MGV series

The motors fed by converters are subject to higher stresses than in case of sinusoidal power supply. The combination of fast switching inverters with cables will cause over voltage due to the transmission line effects. The peak voltage is determined by the voltage supply, the length of the cables and the voltage rise time. As an example, with a rise time of 200 ns and a 30 m (100 ft) cable, the voltage at the motor terminals is twice the inverter voltage.

The insulation system of the MGV motors is designed to withstand high repetitive pulse voltages and largely exceeds the recommendations of the IEC/TS 60034-25 ed 2.0 2007-03-12 for motors without filters up to 480V AC.

Higher supply voltages are available on request.

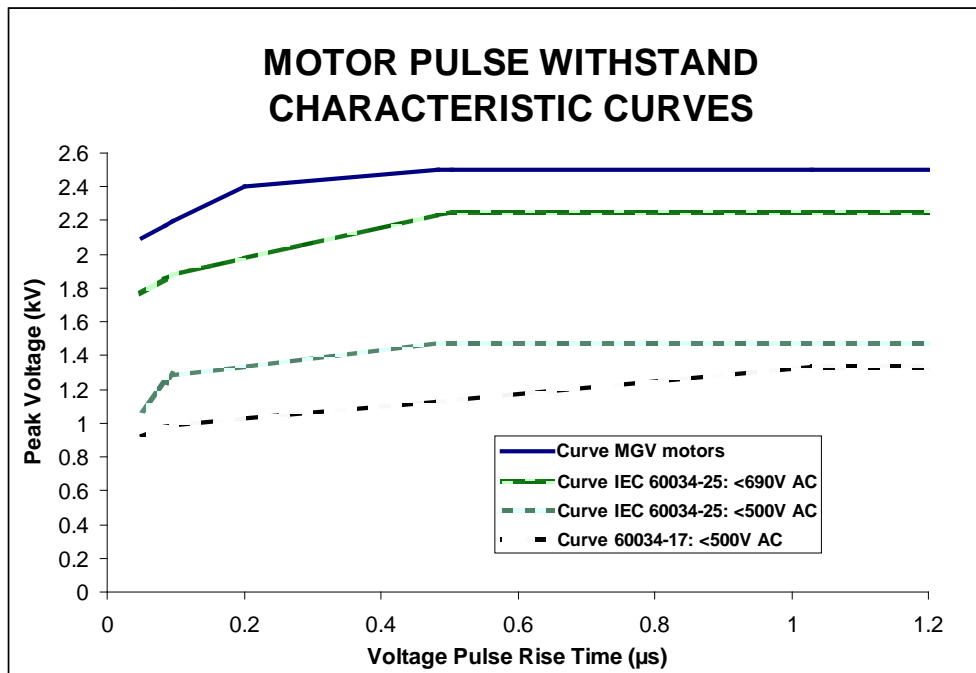

Figure 1: Minimum Voltage withstands characteristics for motors insulations according to IEC standards. At the top are the minimum capabilities for the MGV motors with additional insulation.

Note: The pulse rise times are defined in accordance with the IEC/TS 60034-17 ed4.0 2006-05-09.

The MGV motors can be used with a supply voltage up to 480 V under the following conditions:

- The pulse rise times must be longer than 50 ns.
- The repetitive pulse voltages must not exceed the values given in figure 1, Curve IEC 60034-25 : <500V AC.

### 3.3. Dimension drawings

#### 3.3.1. General outline drawings



These mechanical values can be subject to modifications

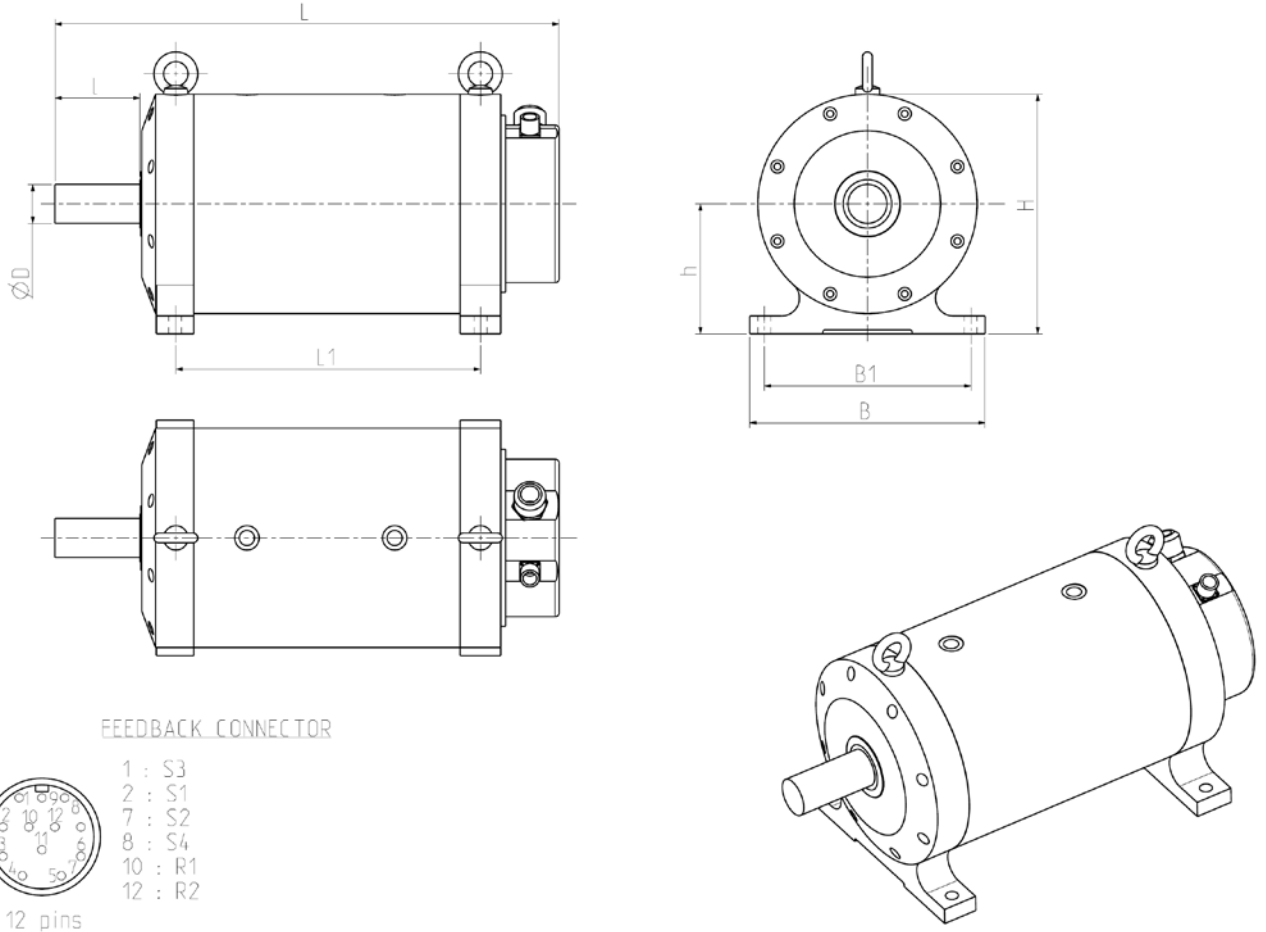

Motor	L	L1	B	B1	H	h	l	Dk6	Weight
	mm	mm	mm	mm	mm	mm	mm	mm	Kg
MGV420	343	192	150	125	150	80	50	24	30
MGV430	376	225	150	125	150	80	50	24	33
MGV620	384	215	160	140	170	90	58	32	41
MGV635	444	275	160	140	170	90	58	32	50
MGV820	451	254	220	190	217	112	80	38	80
MGV840	531	334	220	190	217	112	80	38	100
MGV930	930	376	290	254	295	160	110	48	195
MGV950	1050	496	290	254	295	160	110	48	250
MGV970	1250	658	290	254	295	160	110	42	270
MGVA30	1150	400	312	277	313	160	140	65	300
MGVA50	1300	650	312	277	313	160	140	65	400

### 3.4. Motor mounting

#### 3.4.1. Motor mounting

By flange and feet

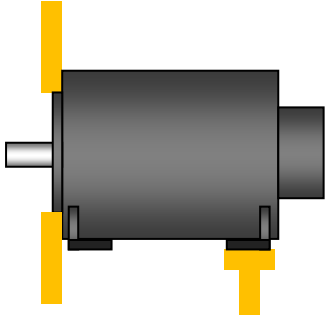

By feet

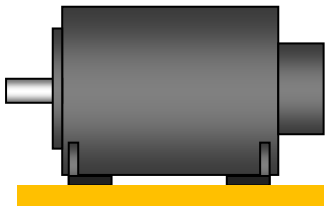

**For vertical mounting, Please consult us.**  
The load capacity and vibration resistance on shaft are different than horizontal mounting.

#### 3.4.2. Typical mounting.

**Warning : The load must be supported by bearings.**  
No additional weight must be mounted on the shaft, even if this weight generates a force lower than the maximum force allowed on the shaft. Indeed, this weight can reduced the shaft resonance frequency and leads to its failure.

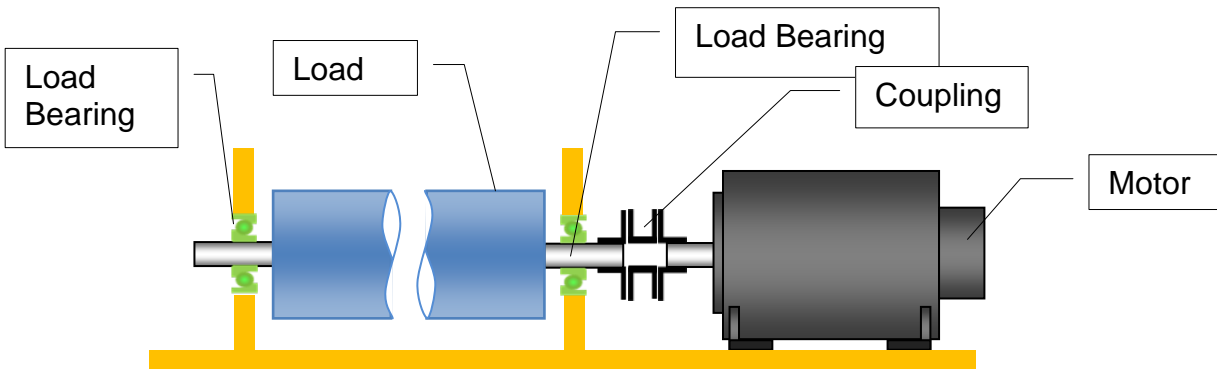



### 3.4.3. Frame recommendation

	<p><u>Warning</u> : The user has the entire responsibility to design and prepare the support, the coupling device, shaft line alignment, and shaft line balancing.</p>
---	--

Foundation must be even, sufficiently rigid and shall be dimensioned in order to avoid vibrations due to resonance.

The high-speed motors need a rigid support, machined and of good quality.

The maximum flatness of the support has to be lower than 0.05mm.

The motor vibration magnitudes are in accordance with CEI 60034-14 – grade A:

- maximum vibration velocity for MGV4/MGV6/MGV8 is 1.3mm/s for rigid mounting
- maximum vibration velocity for MGV9/MGVA is 1.8mm/s for rigid mounting

	<p><u>Warning</u> : A motor well-balanced in itself and of a grade A conforming with CEI 60034-14, may exhibit large vibrations when installed in-situ arising from various causes, such as unsuitable foundations, reaction of the driven motor, current ripple from the power supply, etc. Vibration may also be caused by driving elements with a natural oscillation frequency very close to the excitation due to the small residual unbalance of the rotating masses of the motor. In such cases, checks should be carried out not only on the machine, but also on each element of the installation. (See ISO 10816-3).</p>
--	--

### 3.4.4. Motor alignment

To align easily the motor and the load, we recommend adding screws to push the motor smoothly. Enough screws must be used to move the motor (or the load) in all directions. At each step of the setting, wedges have to be inserted between the motor feet and the frame.

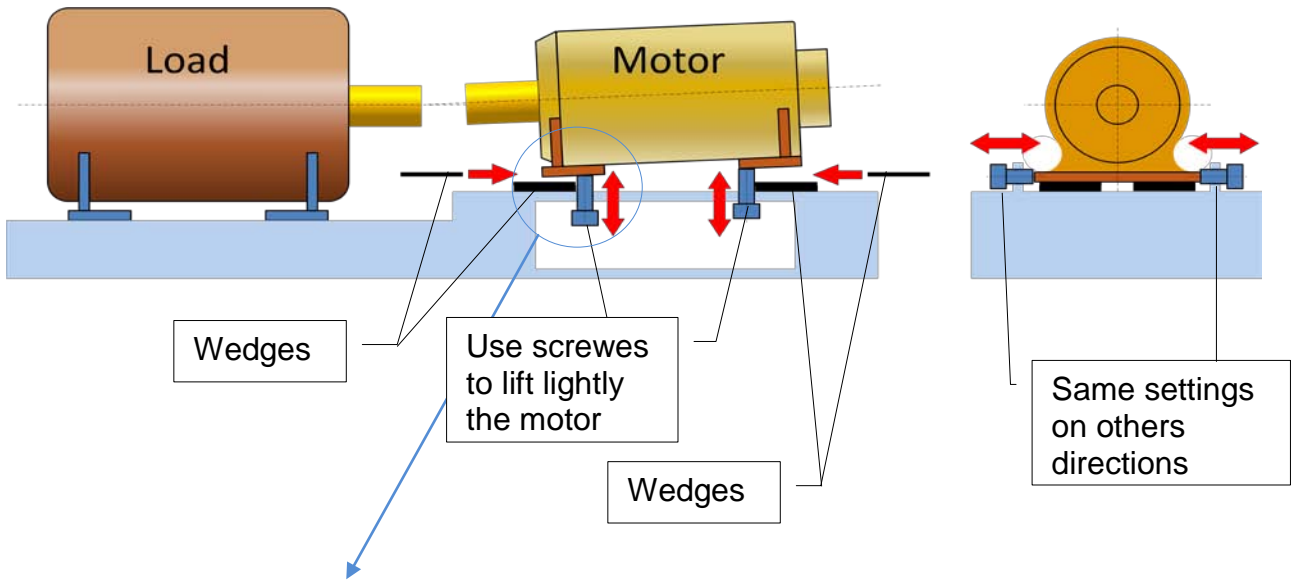

### 3.4.5. Coupling

The permitted loads on the shaft are limited to low values low level (excepted with specific bearing), it is mandatory to use a flexible coupling between the motor and the load.





Different kind of couplings can be used like bellow coupling or disc coupling. They offer hard torsion stiffness.



To fit the coupling on the shaft, we recommend using shrink disc or locking assembly. Other devices like keyways are unbalanced and are not compatible with the high speed.

	<p>To choose the coupling, all the components of the shaft line must be taken into account: motor, load, load's bearings, coupling, speed, acceleration, balancing, alignment.... The coupling supplier can help to define the best coupling.</p>
---	---

	<p><u>Warning</u>: The coupling misalignment generates strains and loads on motor shaft depending on the stiffness of the coupling. Thermal expansion can also generate strain and load. These forces (axial and radial) must be below the maximum shaft allowed forces (§3.4).</p>
---	---

	<p><u>Warning</u> : Parker will not be responsible for any motor shaft failure due to excessive strains on the shaft .</p>
---	--

### 3.4.6. Pulley/belt

	<p><u>Warning</u> : The MGV motors are not designed to operate with pulley / belt systems. By limiting the speed and/or using specific bearing assemblies, it can be possible in some cases to use pulley / belt systems. It is mandatory to raise a request to the factory before doing so.</p>
---	--

### 3.4.7. Vibration and bearings temperature control

It is highly recommended to implement a vibratory control in accordance with the ISO 10816 standard to detect any sign of mechanical evolution before breakdown.

Accelerometers must be located closed to the bearings

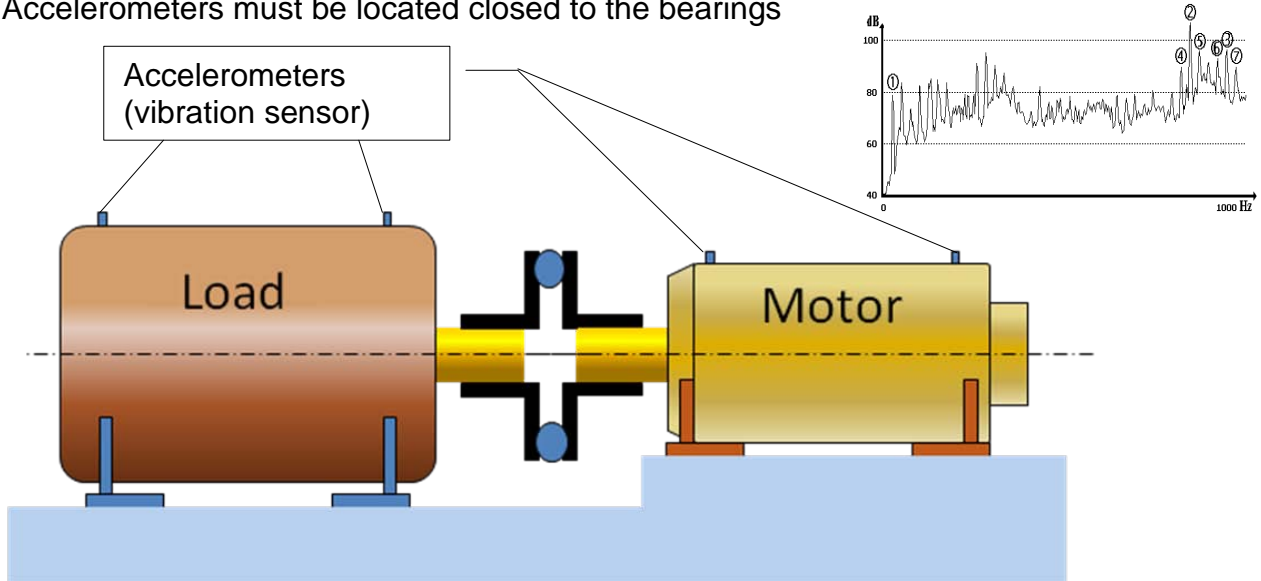

Moreover, it is highly recommended to monitor the bearings temperature. This control can detect temperature evolutions that are the first signs of the bearings end life. We recommend the process below:

- record initial bearing temperature after 1 hour of running.
- calculate the temperature rise = bearing temperature – ambient temperature.
- if temperature rise increase by 15°C during the machine life, the motor must be stopped.

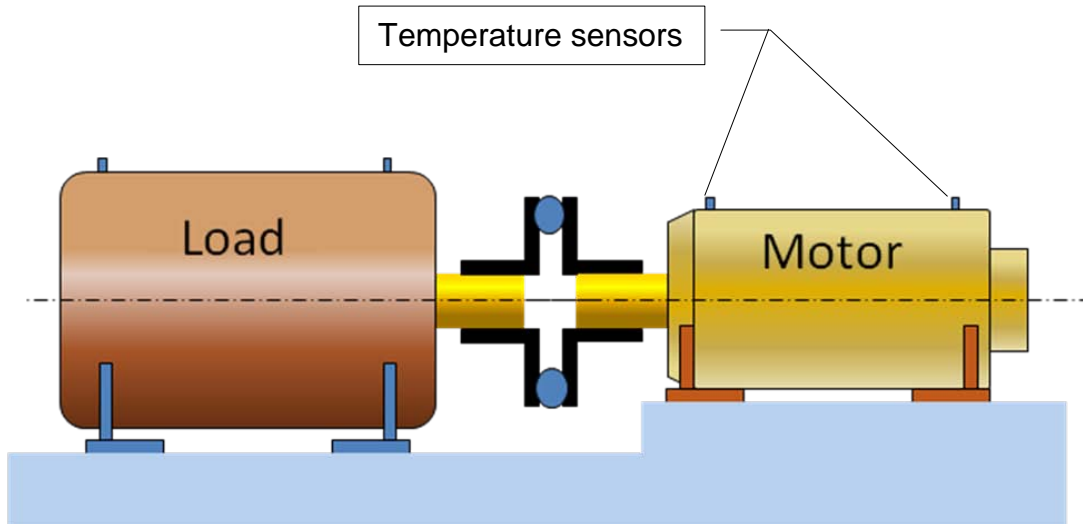

### 3.4.8. Vibration resistance to shaft end

Frequency domain :10 to 55 Hz according to EN 60068 -2-6

Vibration resistance to the shaft end :

- radial 0.9 g
- axial 0,3 g

### 3.5. Bearings

The bearings are greased for life.

The statistic bearings life is limited from 6000h up to 10000h depending on the way there are assembled and used, it is recommended to control the vibrations every 3000h or to change it once the predicted lifetime is reached.

This period is indicative and has to be considered with the load and speed limits taken into account for the bearings calculation.

Depending on the maximum speed, the loads and the needed lifetime, those high-speed motors can be equipped with different kind of bearings: steel ball bearings, hybrid ball bearings (ceramic balls with a synthetic cage) or Xlife bearings (ceramic balls with rings made with high performance iron).

	Possible speed and load depending on bearing type
---	---

	Other limitations can come from the winding or the drive (cf: §3.1.4-Drive selection)
--	---

#### Max possible speed tab depending on bearing type







**FOR HORIZONTAL MOUNTING ONLY**

Motor	STEEL STRAIGHT BEARINGS			HYBRID BEARINGS			X LIFE BEARINGS		
	Max speed rpm	Radial load N	Axial load N	Max speed rpm	Radial load N	Axial load N	Max speed rpm	Radial load N	Axial load N
MGV420	26000	100	30	33000	100	30	45000	100	20
MGV430	26000	100	30	33000	100	30	45000	100	20
MGV620	18500	320	80	25000	320	80	30000	240	60
MGV635	18500	320	80	25000	320	80	30000	240	60
MGV820	14300	400	100	18000	400	100	24000	400	100
MGV840	14300	400	100	18000	400	100	24000	400	100
MGV930	11700	500	120	16000	700	160	20000	500	120
MGV950	11700	500	120	16000	700	160	20000	500	120
MGV970	-	-	-	-	-	-	12000	200	500
MGVA30	9200	700	120	12000	700	120	-	-	-
MGVA50	9200	700	120	12000	700	120	-	-	-

### 3.6. Cooling

In compliance with the CEI 60034-1 standards:

#### 3.6.1. General recommendations

	<p><u>Danger:</u> The cooling system has to be operational when the motor is running or energized.</p>
	<p><u>Danger:</u> The Inlet temperature and the water flow have to be monitored to avoid any damage.</p>
	<p><u>Caution:</u> When motor is not running, the cooling system has to be stopped 10 minutes after the motor shut down.</p>
	<p><u>Caution:</u> Condensation and risk of rust may occur when the temperature gradient between the air and the water becomes significant. Condensation is also linked to hygrometry rate. To avoid any issue, we recommend: <math>T_{\text{water}} &gt; T_{\text{air}} - 2^{\circ}\text{C}</math>. The moteur can be used with an ambient temperature between 27°C to 40°C with a high water temperature but with derating. If inlet water temperature becomes higher than 25°C, derating factor must be apply following §3.1.2 Temperature Derating</p>
	<p><u>Caution:</u> the ambient air temperature shall not exceed 40°C in the vicinity of the motor flange.</p>
	<p><u>Danger:</u> If the water flow stops, the motor can be damaged or destroyed causing accidents.</p>

### 3.6.2. Additives for water as cooling media

Please refer to motor technical data for coolant flow rates.

The water inlet temperature must not exceed **25°C** to get the full performances.

The inner pressure of the cooling liquid must not exceed **5 bars**.

	<p><u>Caution:</u> To avoid the corrosion of the motor cooling system (aluminum or steel), the water must have anti-corrosion additive.</p>
---	---

The spindle servomotors are water cooled. Corrosion inhibitors must be added to the water to avoid the corrosion. The complete cooling system must be taken into account to choose the right additive, this includes: the different materials in the cooling circuit, the chiller manufacturer recommendations, the quality of the water... The right additive solution is the responsibility of the user. Some additives like TYFOCOR or GLYSANTIN G48 correctly used have demonstrated their ability to prevent corrosion in a closed cooling circuit

For example: Glysantin G48 recommendations are :

- Water hardness: 0 to 20°dH (0 – 3.6 mmol/l)
- Chloride content: max. 100ppm
- Sulphate content: max. 100ppm

	<p><u>Caution:</u> The water quality is very important and must comply with supplier recommendations. The additive quantity and periodic replacement must respect the same supplier recommendations.</p>
---	--

	<p><u>Caution:</u> The additive choice must take into account the global cooling system (chiller or water exchanger recommendations...).</p>
---	--

	<p>Select carefully the materials of all the cooling system parts (chiller, exchanger, hoses, adapters and fittings) because the difference between material galvanic potential can generate corrosion.</p>
---	---

### 3.6.3. Motor cooling circuit data

MGV servomotors are cooled by water. An anti-corrosion product must be mixed to the water. The main characteristics of cooling are given in the table below:

Motor	Average flow necessary for cooling (water : 75% minimum)	Maxi drop pressure @ nominal water flow	Motor power losses at max speed and continuous operation	Maximum inlet cooling temperature	Maximum outlet cooling temperature
	L/min	Bars	kW	°C	°C
MGV420	2	3 maxi	0,75	25	31
MGV430	3		1,1	25	31
MGV620	3		1,2	25	31
MGV635	5		1,8	25	31
MGV820	5		1,7	25	31
MGV840	10		5	25	32
MGV930	10		4	25	31
MGV950	16		6,4	25	31
MGV970	22		12	25	32
MGVA30	18		6	25	30
MCVA50	25		10	25	31

### 3.6.4. Chiller selection

Chiller must be able to evacuate motor power loss (see table above).  
 Chiller pump must provide water flow through motor and pipe pressure drop.  
 Inlet temperature must be inferior to 25°C.

You can find various chillers solutions in Parker Hiross - <http://www.dh-hiross.com/>

Contact:

PASCAL TANCHAUD

Cooling Technology Manager

pascal.tanchaud@parker.com



### 3.6.5. Flow derating according to glycol concentration

	Glycol concentration [%]					
	0	10	20	30	40	50
5	5.1	5.3	5.6	5.9	6.2	
10	10.2	10.6	11.1	11.8	12.4	
15	15.3	15.9	16.7	17.6	18.7	
20	20.4	21.2	22.2	23.5	24.9	
25	25.5	26.5	27.8	29.4	31.1	
30	30.6	31.8	33.4	35.3	37.3	
35	35.7	37.1	38.9	41.1	43.6	
40	40.8	42.4	44.5	47.0	49.8	
45	45.9	47.7	50.0	52.9	56.0	
50	51.0	53.0	55.6	58.8	62.2	
55	56.1	58.3	61.2	64.7	68.4	
60	61.2	63.5	66.7	70.5	74.7	
65	66.4	68.8	72.3	76.4	80.9	
70	71.5	74.1	77.8	82.3	87.1	
75	76.6	79.4	83.4	88.2	93.3	
80	81.7	84.7	89.0	94.1	99.5	
85	86.8	90.0	94.5	99.9	105.8	
90	91.9	95.3	100.1	105.8	112.0	
95	97.0	100.6	105.6	111.7	118.2	
100	102.1	105.9	111.2	117.6	124.4	
110	112.3	116.5	122.3	129.3	136.9	
120	122.5	127.1	133.4	141.1	149.3	
130	132.7	137.7	144.6	152.8	161.8	
140	142.9	148.3	155.7	164.6	174.2	
150	153.1	158.9	166.8	176.3	186.6	
160	163.3	169.5	177.9	188.1	199.1	
170	173.5	180.1	189.0	199.9	211.5	
180	183.7	190.6	200.2	211.6	224.0	
190	194.0	201.2	211.3	223.4	236.4	
200	204.2	211.8	222.4	235.1	248.9	

#### Use of the table above - Example

If the motor needs **25 l/min** with **0%** glycol,

If application needs **20%** glycol, the water flow must be **26.5 l/min**,

If application needs **40%** glycol, the water flow must be **29.4 l/min**.



### Main formulas

$$\text{Flow\_rate} = \frac{\text{Power\_dissipation} * 60}{\Delta\theta^\circ * C_p}$$

With: *Flow rate* [l/min]  
*Power\_dissipation* [kW]  
 $\Delta\theta^\circ$  Gradient inlet-outlet [°C]  
**C<sub>p</sub>** thermal specific capacity of the water as coolant [J/kg°K]  
(**C<sub>p</sub>** depends on the % glycol concentration please see below)

### Thermal specific capacity C<sub>p</sub> according to % glycol concentration and temperature

We have considered an average temperature of the coolant of 30°C.

Glycol concentration [%]	Average temperature of the water as coolant [°C]	Thermal specific capacity of the water <b>C<sub>p</sub></b> [J/kg°K]
0	30	4176
30	30	3755
40	30	3551
50	30	3354

### 3.6.6. Water cooling diagram

	<p><b>Recommendation:</b> The use of a filter allows reducing the presence of impurities or chips in the water circuit in order to prevent its obstruction. We recommend a 0.1mm filter.</p>
--	--

This section shows typical water cooling diagram:

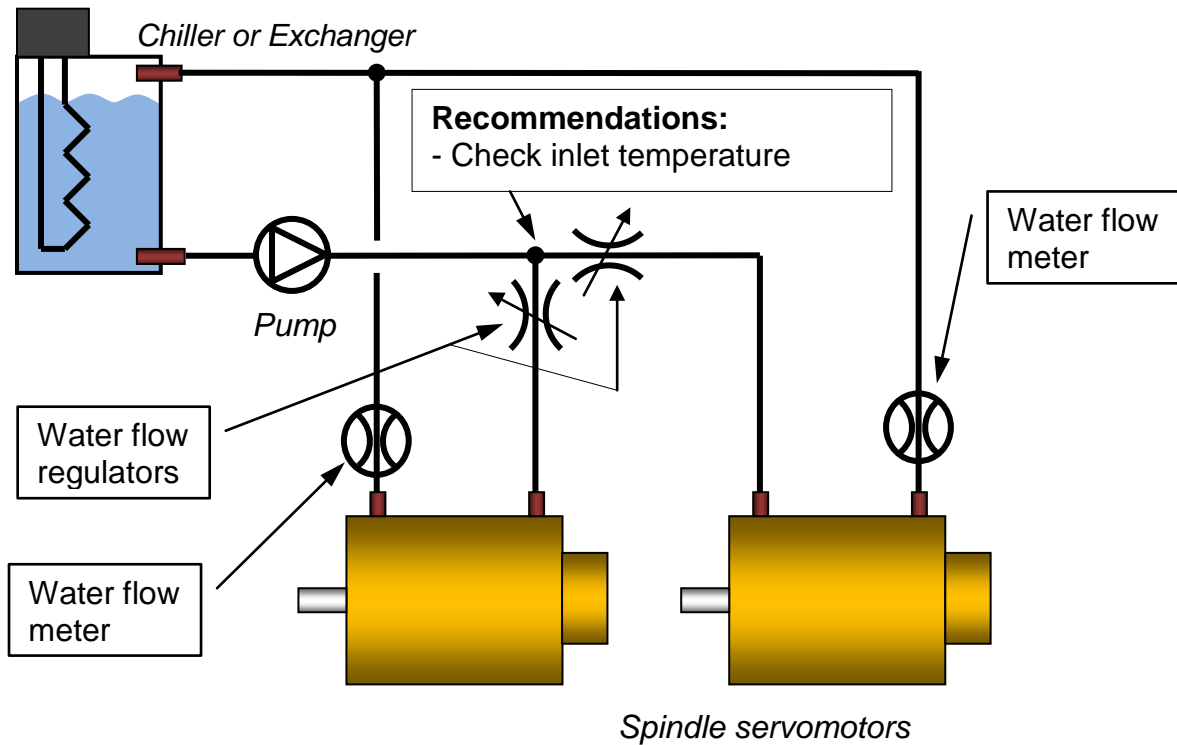
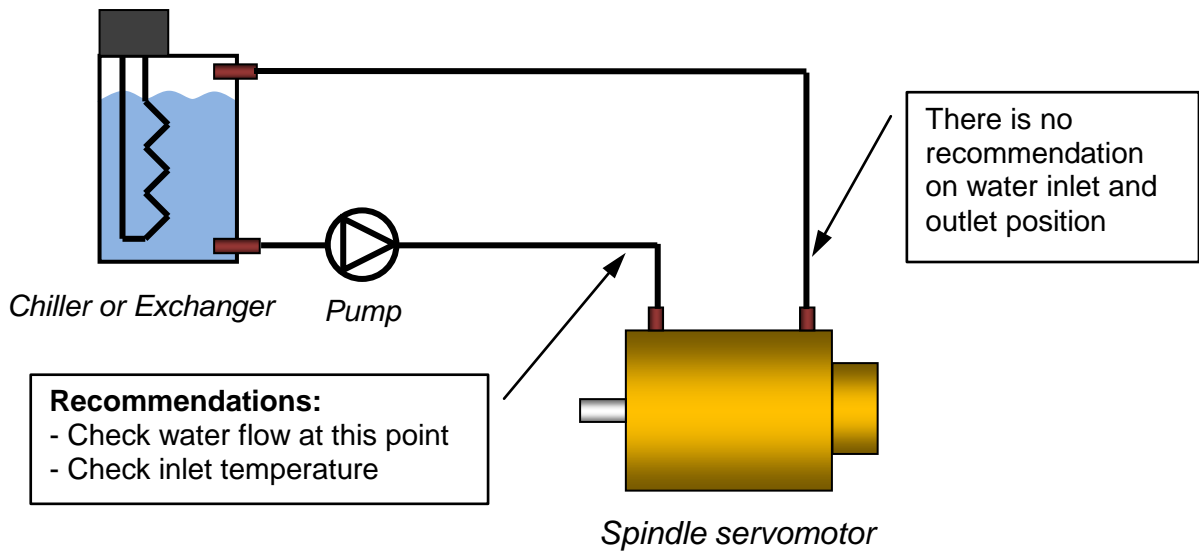

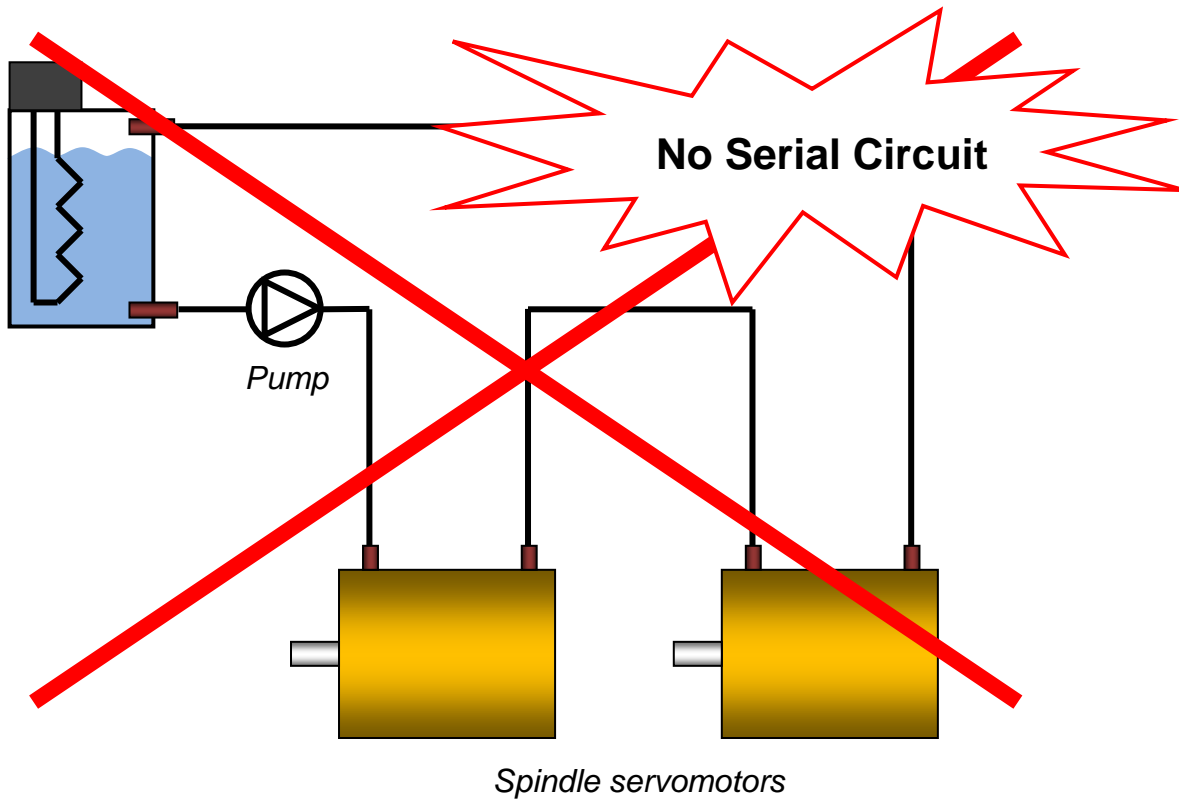
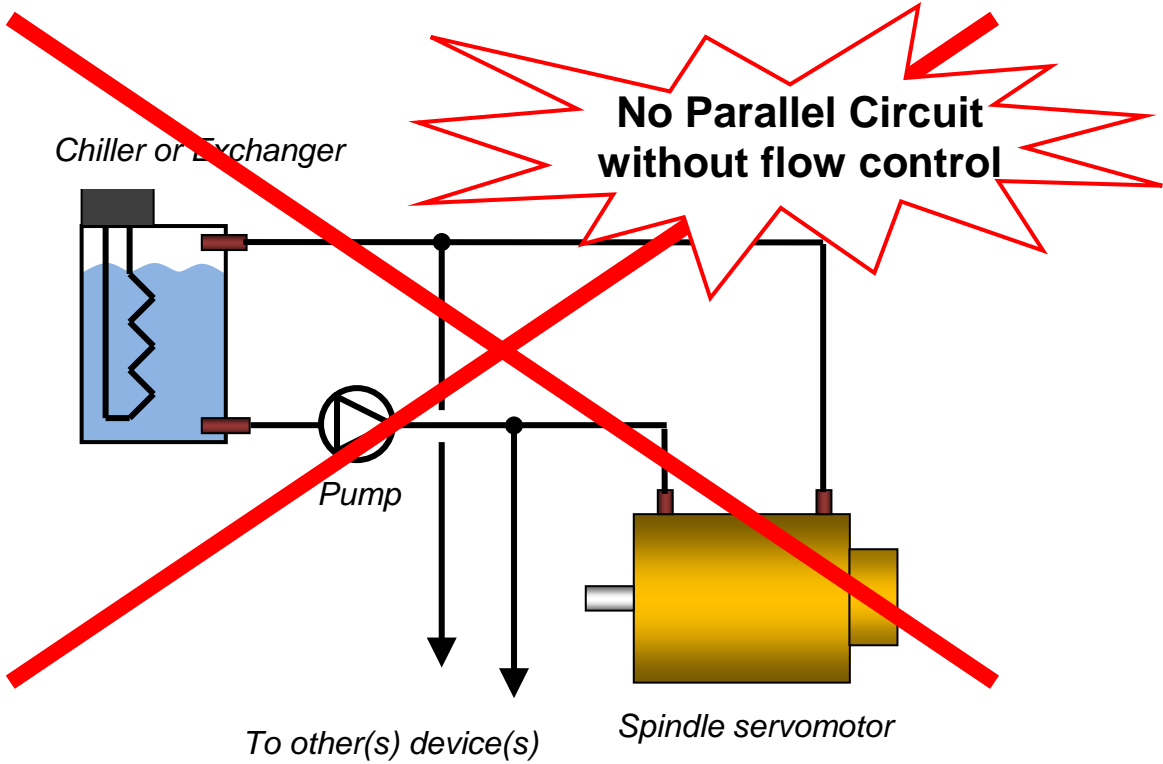

### 3.7. Thermal Protection

Protection against thermal overloading of the motor is provided by two PTC thermistors and one KTY temperature sensor (and one more in case of KTY failure) built into the stator winding as standard.

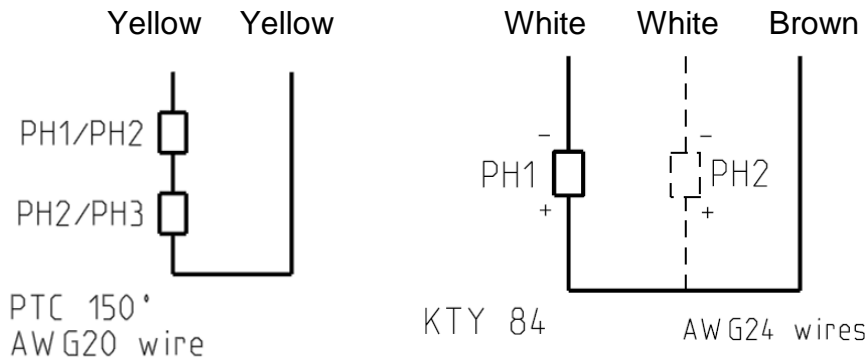

#### 3.7.1. Alarm tripping with PTC thermistors :

The thermal probes (PTC thermistors) fitted in the servomotor winding trip the electronic system at  $150^{\circ} \pm 5^{\circ} \text{C}$ . When the rated tripping temperature is reached, the PTC thermistor resistance changes very quickly. This resistance can be monitored by the drive to protect the motor.

The graph and tab below shows the PTC resistance as a function of temperature ( $T_N$  is nominal temperature)

Temperature	Resistance value
-20°C up to $T_N - 20^{\circ}\text{C}$	$R \leq 500\Omega$
$T_N - 5^{\circ}\text{C}$	$R \leq 1100\Omega$
$T_N + 5^{\circ}\text{C}$	$R \geq 2660\Omega$
$T_N + 15^{\circ}\text{C}$	$R \geq 8000\Omega$

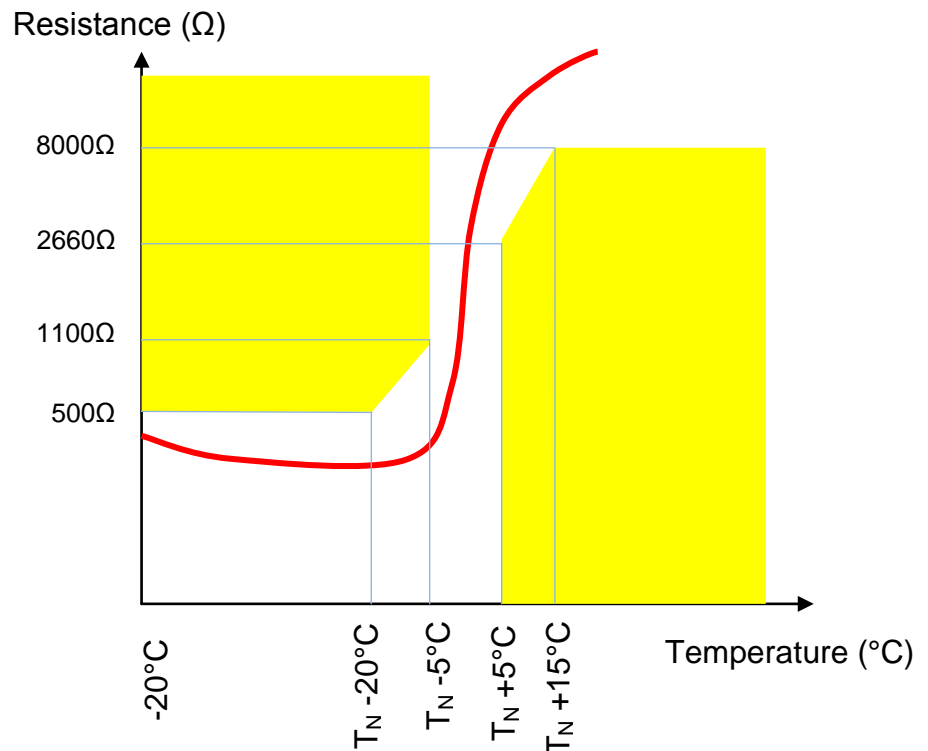

### 3.7.2. Temperature measurement with KTY sensors:

Motor temperature can also be continuously measured by the drive using a KTY 84-130 thermal sensor built in to the stator winding. KTY sensors are semiconductor sensors that change their resistance according to an approximately linear characteristic. The required temperature limits for alarm and tripping can be set in the drive.

The graph below shows the KTY sensor resistance as a function of temperature, for a current of 2 mA:

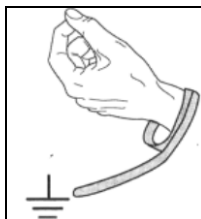
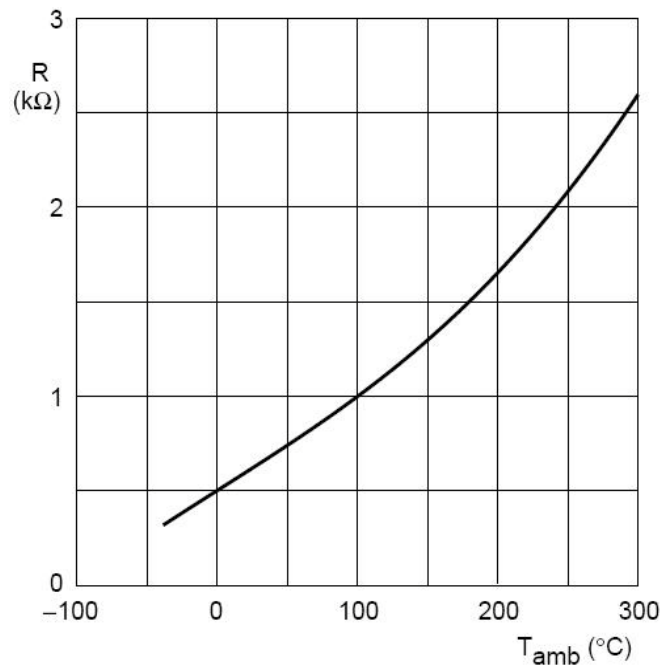

Warning: KTY sensor is sensitive to electrostatic discharge. So, always wear an antistatic wrist strap during KTY handling.



Warning: KTY sensor is polarized. Don't invert the wires.



Warning: KTY sensor is sensitive. Don't check it with a Ohmmeter or any measuring or testing device.

### 3.8. Power electrical connection

#### 3.8.1. Wires sizes



In every country, you must respect all the local electrical installation regulations and standards.

Not limiting example in France: NFC 15-100 or CEI 60364 as well in Europe.



Cable selection depends on the cable construction, so refer to the cable technical documentation to choose wire sizes



Some drives have cable limitations or recommendations; please refer to the drive technical documentation for any further information.

#### Cable selection



At standstill, the current must be limited at 80% of the low speed current  $I_o$ . And the cable has to support the peak current for a long period. So, if the motor works at standstill, the current to select the right wire size is  $\sqrt{2} \times 0.8 I_o \cong 1,13 \times I_o$ .

#### Sizes for H07 RN-F cable at 40°C

Section [mm <sup>2</sup> ]	$I_{max}$ [A <sub>rms</sub> ]	Resistance [Ω/Km]
4	23	4.250
6	30	2.833
10	40	1.700
16	54	1.063
25	71	0.680
35	87	0.486
50	106	0.340
70	134	0.243
95	163	0.179
120	189	0.142
150	217	0.113
185	247	0.092
240	291	0.071
300	334	0.057



Example of sizes for H07 RN-F cable :

Conditions of use:

Case of single conductors type H07 RN-F: **60°C maximum**

Ambient temperature: 40°C

Cable runs on dedicated cables ways

Current limited to  $80\% \cdot I_0$  at low speed or at motor stall.

Example:

$I_0=100$  Arms

Permanent current at standstill : 80 Arms

Max permanent current in the cable = 113 Arms

Cable section selection = 70mm<sup>2</sup>

You also have to respect the Drive commissioning manual and the cables current densities or voltage specifications

**3.8.2. Conversion Awg/kcmil/mm<sup>2</sup>:**

Awg	kcmil	mm <sup>2</sup>
	500	253
	400	203
	350	177
	300	152
	250	127
0000 (4/0)	212	107
000 (3/0)	168	85
00 (2/0)	133	67.4
0 (1/0)	106	53.5
1	83.7	42.4
2	66.4	33.6
3	52.6	26.7
4	41.7	21.2
5	33.1	16.8
6	26.3	13.3
7	20.8	10.5
8	16.5	8.37
9	13.1	6.63
10	10.4	5.26
11	8.23	4.17
12	6.53	3.31
14	4.10	2.08
16	2.58	1.31
18	1.62	0.82
20	1.03	0.52
22	0.63	0.32
24	0.39	0.20
26	0.26	0.13



### 3.8.3. Motor cable length

For motors which present low inductance values or low resistance values, the own cable inductance, respectively own resistance, in case of large cable length can greatly reduce the maximum speed or/and the maximum power of the motor. Please contact Parker for further information.



Caution: It might be necessary to fit a filter at the servo-drive output if the length of the cable exceeds 25 m. Consult us.

### 3.8.4. Ground connection



DANGER: For the safety, you need to connect motor to the ground. Consult the local regulations to choose the right cross section and to know the resistance limits to check ground continuity between frame and ground wire.

### 3.8.5. Motor cable

The electrical connection on MGV motor is realized by high performance cable. The motor cable section depends on the motor current level. Please refer to the outline drawing to know the cross section (depending of torque/speed characteristics letter code).



Caution: The motor cables are designed for high current density, so cable surface can reach or exceed 100°C.



Caution: The wiring must comply with the drive commissioning manual and with the recommended cables.

Caution: Section motor cable is lower than commissioning section cable between motor and drive due to high performance motor cable design. Don't use the same cable section than the motor ones.

### 3.9. Feedback system

#### 3.9.1. Resolver

A resolver determines the rotor position.

Its signals are processed by the drive in order to control the stator currents, the speed and the position.

Two resolver types can be associated with the MG: CB52 or CB102 with a connector seat.

	<b>CB52</b>	<b>CB102</b>
<b>Motor associated</b>	<b>MGV4 / MGV6 / MGV8</b>	<b>MGV9 / MGVA</b>
Maximum speed	50 000 rpm	20 000 rpm
Number of pole	2 poles	2 poles
Feeding voltage at 8 KHz	7 Vrms	7 Vrms
Feeding current at 8 KHz	70mA maximum	70mA maximum
Precision under 7Vrms at 8KHz	+/-6'	+/-10'
Transformation ratio at 8 KHz	0.425 mini, 0.55 maxi	0.425 mini, 0.55 maxi
Input DC resistance, supply transformer (R1-R2)	Mini 24 Ω Maxi 26 Ω	Mini : 15.1 Ω Maxi : 16.2 Ω
DC stator resistance output sin (S2-S4) output cos (S1-S3)	Mini 34.5 Ω Maxi 37.5 Ω	Mini 57.4 Ω Maxi 63Ω
Insulation resistance	≥ 50MΩ	≥ 50MΩ
Assembly	Direct on shaft end	Direct on shaft end
Operating temperature	-55 – +155 °C	-55 – +155 °C

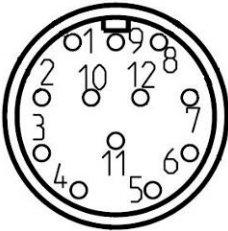
<b>Resolver connector</b>	<b>PIN</b>	<b>Signal</b>
	1	Output voltage S3 (cos-)
	2	Output voltage S1 (cos+)
	3	
	4	
	5	
	6	
	7	Output voltage S2 (sin+)
	8	Output voltage S4 (sin-)
	9	
	10	Input voltage R1
	11	
	12	Input voltage R2



### **3.9.2. Cables and connectors associated to the resolver**

Cable reference for DIGIVEX drive: CD1UA1F1R0xxx depending on length  
Cable reference for AC 890 drive: CS4UA1F1R0xxx depending on length.  
The "xxx" in the part number must be replaced by the length in meter.  
Ex : for 20m cable, "xxx" = 020.

Resolver connector reference for seat, pins to be soldered: 220065R4621  
Resolver straight seat reference, pins to be crimped: 220132P1020

### **3.9.3. Resolver setting**

During the setting procedure, it is strictly necessary to respect the 3 following conditions:

- The rotor must be able to rotate freely. The maximum friction torque on the rotor must not exceed 1% of the motor permanent torque.
- The cooling circuit has to be in use.
- The operator must be able to reach the resolver stator and to manually turn it and lock it (access to the locking screws).

Look at the drive instruction manual for the setting procedure details.

### **3.9.4. Sin-Cos Encoder (on request)**

1V~, 250Khz max

**Restriction:** As the encoder is not absolute on one turn, the setting is lost at each power OFF. You must either set the encoder at each power ON or keep alive the low power supplies.

The advantage of the sin-cos encoder is the excellent accuracy that allows very good power, speed and position control.

## 4. COMMISSIONING AND USE

### 4.1. Reception, handling, storage

#### 4.1.1. Equipment delivery

All the high-speed motors are strictly controlled during manufacturing, before shipping. While receiving it, it is necessary to verify motor condition and if it has not been damaged in transit. Remove it carefully from its packaging. Verify that the data written on the label are the same as the ones on the acknowledgement of order, and that all documents or needed accessories for user are present in the packaging.



**Warning :** In case of damaged material during the transport, the recipient must **immediately** make reservations to the carrier through a registered mail within 24 h.

#### 4.1.2. Handling

The high-speed motors are equipped with 2 lifting rings for handling.



**DANGER:** Only use the lifting rings the high-speed motors are equipped with for handling operations. Never use cables, connectors, input/output of cooling circuit, or any other inappropriate lifting device.

The picture hereunder shows the correct way for handling the high-speed motors.

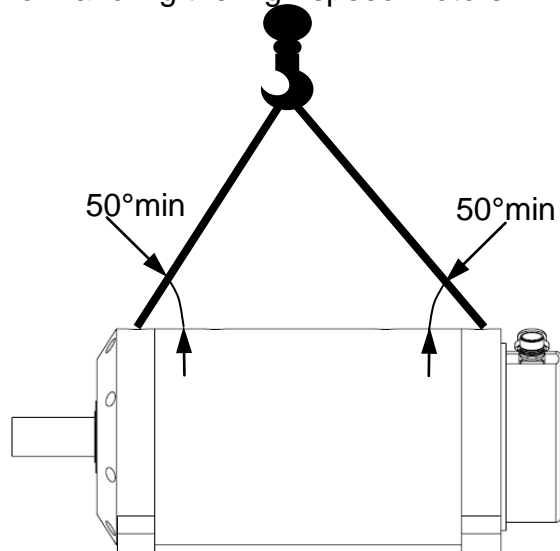
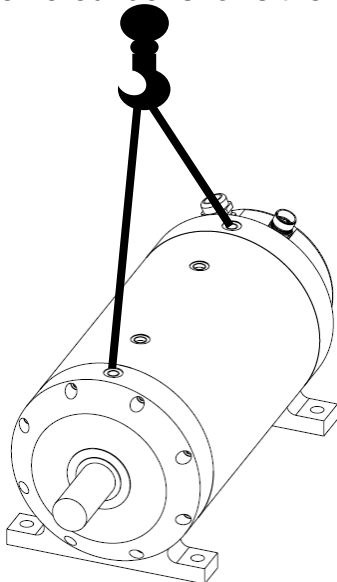

**DANGER:** Choose the correct slings for the motor weight. The two slings must be the same length and a minimum angle of 50° has to be respected between the motor axis and the slings.

### 4.1.3. Storage

Before being mounted, the high-speed motor has to be stored in a dry place, without hard temperature variation in order to avoid condensing.

During storage, the ambient temperature must be kept between -20 and +60°C.

If the high-speed motor has to be stored for a long time, verify that the shaft end, feet and the flange are coated with corrosion proof product.

After a long storage duration (more than 3 month), run the motor at low speed in both directions, in order to blend the bearing grease spreading.

The motor is delivered with caps for the water inlet and outlet to protect the cooling circuit. Keep them on place until the motor commissioning.

## 4.2. Installation

### 4.2.1. Mounting

Foundation must be even, sufficiently rigid and shall be dimensioned in order to avoid vibrations due to resonance. Before bolting the motor's feet, the foundation surface must be cleaned and checked in order to detect any excessive height difference between the foot locations. The variation from one foot to any other shall not exceed 0,05 mm. In any case we recommend using shims to compensate small irregularities.



Caution: The user bears the entire responsibility for the preparation of the foundation.

The table below gives the average tightening torques required regarding the fixing screw diameter. These values are valid for both motor's feet and flange bolting.

Screw diameter	Tightening torque
M2 x 0.35	0.35 N.m
M2.5 x 0.4	0.6 N.m
M3 x 0.5	1.1 N.m
M3.5 x 0.6	1.7 N.m
M4 x 0.7	2.5 N.m
M5 x 0.8	5 N.m
M6 x 1	8.5 N.m
M7 x 1	14 N.m
M8 x 1.25	20 N.m

Screw diameter	Tightening torque
M9 x 1.25	31 N.m
M10 x 1.5	40 N.m
M11 x 1.5	56 N.m
M12 x 1.75	70 N.m
M14 x 2	111 N.m
M16 x 2	167 N.m
M18 x 2.5	228 N.m
M20 x 2.5	329 N.m
M22 x 2.5	437 N.m
M24 x 3	564 N.m



Warning: After 15 days, check all tightening torques on all screws and nuts.

#### 4.2.2. Preparation

Once the motor is installed, it must be possible to access to the wiring, and read the manufacturer's plate. Air must be able to circulate freely around the motor for cooling purposes.

Clean the shaft using a cloth soaked in white spirit or alcohol. Pay attention that the cleaning solution does not get on to the bearings.

The motor must be in a horizontal position during cleaning or running.



Caution: Do not step on the motor, the connector or the terminal box



Caution: Always bear in mind that some parts of the surface of the motor can reach or exceed 100°C

#### 4.2.3. Mechanical assembly

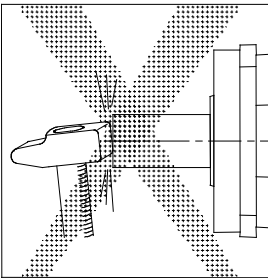

The operational life of High-speed motor bearings largely depends on the care and attention given to this operation.

- Carefully check the alignment of the motor shaft with the driven machine to avoid vibrations, irregular rotations or applying too much strain on the shaft.
- Prohibit any impact on the shaft or press fitting which could mark the bearing tracks.
- In the event that the front bearing block is sealed by a lip seal which rubs on the rotating section, we recommend that you lubricate the seal with grease to extend its operational life.

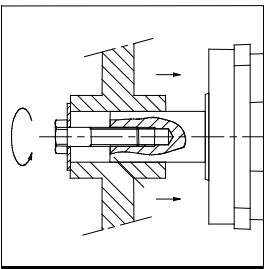

Warning : The user has the entire responsibility to prepare the support, the coupling device, shaft line alignment, and shaft line balancing.

#### 4.2.4. Alignment

In order to control the loads applied on the motor shaft, the shafts must be aligned very carefully, even if a flexible coupling system is used.

The operation has to set:

- Axial alignment a

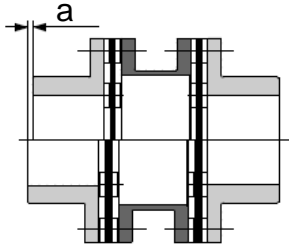

Radial alignment r

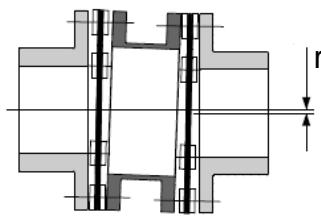

Angular alignment b

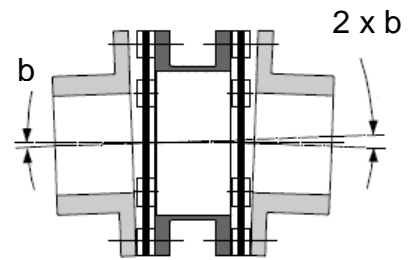

As the total misalignment is a combination of the three misalignments (axial, radial, angular), don't exceed, for each setting, 20% of the maximum value given by the coupling device manufacturer.

The efforts on the shaft due to misalignments, taking into account the coupling stiffness, must not exceed the specified values given for the motor (see §3.4 "Bearings").

	<p><u>Attention</u> : Coupling misalignment generates strain and load on motor shaft depending on the rigidity of the coupling. Variations in temperature generate strain and load due to the expansion. These forces (axial and radial) must not exceed the specified loads (§3.4). Coupling misalignment generates also vibrations.</p>
--	---

	<p><u>Danger</u> : Coupling misalignment generates vibrations that can lead to a shaft failure.</p>
--	---

	<p><u>Warning</u> : Parker will not be responsible for any motor shaft fatigue due to excessive strain on the shaft, a bad alignment or bad shaft line balancing .</p>
--	--

Different solutions are possible to align motor with load:

- With dial gauge :

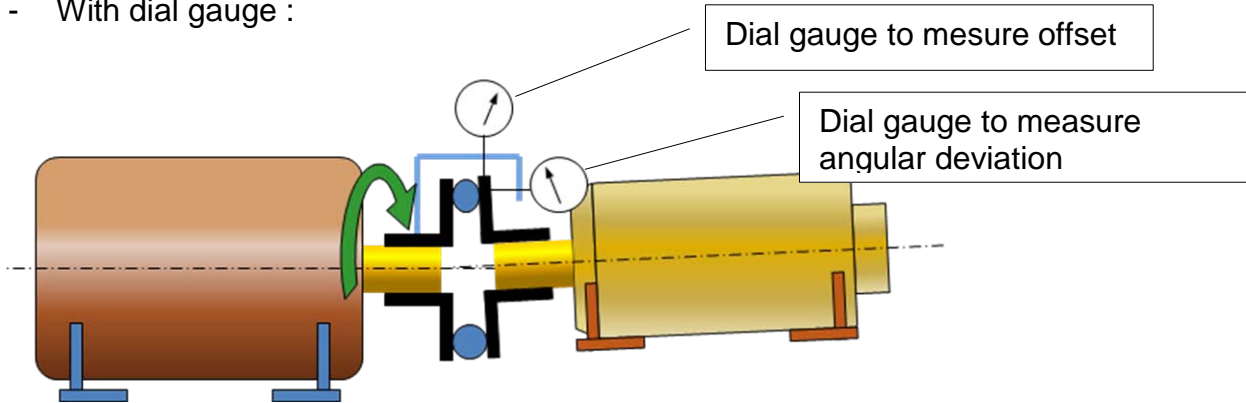

- With laser

A laser alignment is highly recommended for speeds > 10000rpm

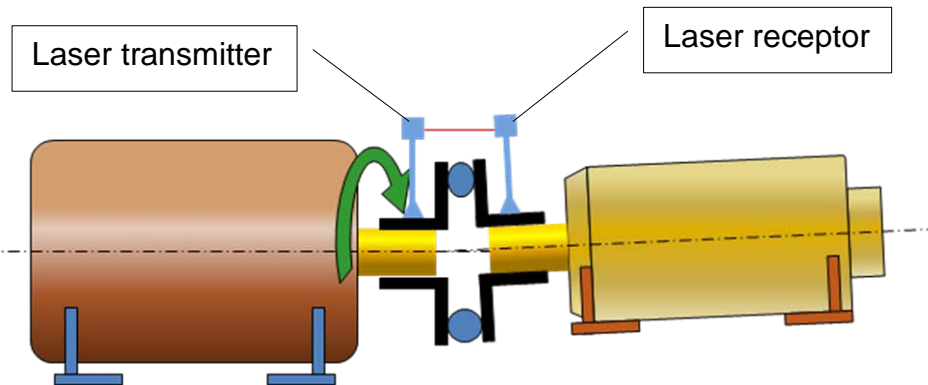

	<p><b>Warning : The load must be supported by bearings.</b> Any weight on the shaft (even below maxi bearing force capacity) cannot be supported by motor bearings: balancing default generates centrifugal force and vibration as a result is breakdown shaft.</p>
--	---

	<p>For the fixed through feet motors, after alignment operation, the wobbly foot has to be steadied before tightening.</p>
--	--



#### **4.2.5. Motor startup**

The delivered motor has been controlled and burned in. Nevertheless, it is recommended to start it gradually by 1000-rpm steps with a speed ramp, during 1 minute for each step until the maximum speed. Monitor the bearing temperature. It must be stabilized. Typical temperatures are 60-70°C.

	<p><u>Attention</u> : Strong speed step without speed ramp can damage bearings or can excite natural frequency.</p>
---	---

#### **4.2.6. Shaft line balancing and vibration control**





Once the motor is fixed on its frame and linked with the driven load, it is highly recommended to check complete shaft line balancing to minimize vibrations.

Moreover, it is highly recommended to implement a vibratory control in accordance with the ISO 10816 standard: the efficient speed vibration on the frequency range between 10 to 1000Hz must not run over 2.8 mm/s for an endless supply.

The motor has to be tested on the whole speed range in order to detect a potential natural frequency with the frame.

Rotation speed for which a resonance appears have to be avoided or the resonance has to be suppressed.

### 4.3. Electrical connection

	<p><u>Warning</u> : Check that the power to the electrical cabinet is safely off prior to make any connections.</p>
	<p><u>Warning</u> : The wiring must comply with the drive commissioning manual, with recommended cables, the standard and the local regulations</p>
	<p><u>Warning</u> : The high-speed motor must be grounded by connecting to an unpainted section of the motor.</p>
	<p><u>Danger</u>: After 15 days, check all tightening torques on cable connection. Bad connections can lead to overheating and fire.</p>

Please, read **§3.7 "Electrical connection"** to have information about cable recommendations.

A lot of information are already available in the drive documentations.

The motor has to be connected to the drive in accordance with its commissioning manual.

Colour codes are as follow:

Signal	Colour
U	black
V	white
W	red
Earth	green/yellow
Thermal sensor KTY84-130 (+)	Brown
Thermal sensor KTY84-130 (-)	White
Thermal protector PTC 150°C	yellow
Thermal protector PTC 150°C	yellow

## 4.4. Maintenance Operations

---

	<p><b>Generality</b>  <b>DANGER:</b> The installation, commissioning and maintenance operations must be performed by qualified personnel, in conjunction with this documentation.</p> <p>The qualified personnel must know the safety (C18510 authorization, standard VDE 0105 or IEC 0364) and local regulations.</p> <p>They must be authorized to install, commissioning and operate in accordance with established practices and standards.</p> <p>Please contact PARKER for technical assistance.</p>
---	--

Operation	Periodicity	Section number
Vibration and bearings temperature checking	Every 3000h	§3.4.7
Alignment checking	Every year	§4.2.4
Cooling water quality inspection	Every year	§3.6
Check all tightening torques on all screws in the terminals box	Every year	§4.2
Clean the motor	Every year	

## 4.5. Troubleshooting

We provide hereunder a symptom list in regard with their possible cause. This is not an exhaustive list so in case of trouble, please refer to the associated servo drive manual (the diagnostic board indications will help you investigating).

<p>You note that the motor does not turn by hand when the motor is not connected to the drive.</p>	<ul style="list-style-type: none"> <li>• Check if the phases are not in short circuit.</li> <li>• Check if the rotor is externally blocked mechanically in rotation.</li> </ul>
<p>You have difficulty to start the motor or to run it.</p>	<ul style="list-style-type: none"> <li>• If there is a thermal protector, check it and its connection and how it is set in the drive.</li> <li>• Check the servomotor insulation (in doubt, measure when the motor is hot and cold).</li> </ul> <p>The minimum insulation resistance measured under 500VDC max is 50 MΩ :</p> <ul style="list-style-type: none"> <li>- Between phase wire and housing,</li> <li>- Between thermal protector and housing,</li> <li>- Between resolver winding and housing.</li> </ul>
<p>You find that the motor is drifting</p>	<ul style="list-style-type: none"> <li>• Adjust the servo amplifier offset.</li> </ul>
<p>You notice that the motor is racing</p>	<ul style="list-style-type: none"> <li>• Check the speed set-point of the servo amplifier.</li> <li>• Check if you have chosen the right regulation mode (torque, speed, position)</li> <li>• Check the resolver setting.</li> </ul>
<p>You notice vibrations</p>	<ul style="list-style-type: none"> <li>• Check the resolver connection, the earth connections and the grounding of the earth wire, the setting of the servo amplifier speed loop and shielding.</li> <li>• Check the stability of secondary voltages.</li> <li>• Check motor fixing on its base.</li> <li>• Check the balancing.</li> <li>• Check the alignment between motor and load.</li> </ul>
<p>You find that the motor is too noisy</p>	<p>Several possible explanations :</p> <ul style="list-style-type: none"> <li>- Unsatisfactory mechanical balancing,</li> <li>- Defective coupling,</li> <li>- Loosening of several pieces,</li> <li>- Poor adjustment of the servo amplifier of the position loop : check rotation with the loop open.</li> <li>- Low drive switching frequency.</li> </ul>